

WEYMOUTH TOWNSHIP MUNICIPAL UTILITIES AUTHORITY

RULES AND REGULATIONS
FOR
FURNISHING WATER AND SEWERAGE SERVICE

TOWNSHIP OF WEYMOUTH
ATLANTIC COUNTY
STATE OF NEW JERSEY

ADOPTED SEPTEMBER 19, 1991

PRICE: \$14.00

5.4 Maintenance by Customer

All connections, service laterals, sewer vents and fixtures furnished by the customer, shall be maintained by him in good order, and all piping and connections furnished and owned by the Authority and on the property of the customer, shall be protected properly and cared for by the customer. All leaks in the service lateral or any other pipe fixture in or upon the premises served, must be repaired immediately by the owner or occupant of the premises. The customer shall be responsible for notifying the Authority of the party engaged by said customer to do any maintenance work in the customer's service lateral, prior to work being commenced, and said party shall not backfill any trench until the work has been inspected and approved by the Authority's representatives. Any work not acceptable shall be immediately removed and replaced by work which is acceptable. The connection or service lateral from the curb to the main shall be maintained by the Authority. The first lateral installed shall be the only lateral to the property maintained by the Authority. All additional laterals shall be maintained by the applicant-owner.

5.5 Authority Not Responsible

The Authority shall in no way be responsible for maintaining any portion of the service lateral owned by the customer, or for damage done by sewage escaping therefrom; or for lines or fixtures on the customer's property; and the customer shall at all times comply with applicable municipal regulations with respect thereto, and make changes therein, required by reason of changes of grade, relocation of mains or otherwise.

5.6 Property Served by Single Service Lateral

A service lateral from the curb, or the main in a right-of-way to a property, shall not serve more than one property, but any such property upon application of the owner, may be served by two or more laterals, such of which, for billing purposes, shall be considered as being one customer account.

5.7 Single Service Lateral with Two or More Customers

Where two or more customers are now served through a single service lateral, any violation of the rules of the Authority, with respect to either or any said customer, shall be deemed a violation as to all, and unless said violation is corrected after reasonable notice, the Authority may take such action as may be taken for a single customer, except that such action will not be taken until a customer who has not violated the Authority's rules has been given a reasonable opportunity to connect his pipe to a separately controlled service lateral.

WEYMOUTH TOWNSHIP MUNICIPAL UTILITIES AUTHORITY

RULES AND REGULATIONS
FOR
FURNISHING WATER AND SEWERAGE SERVICE

TOWNSHIP OF WEYMOUTH
ATLANTIC COUNTY
STATE OF NEW JERSEY

ADOPTED SEPTEMBER 19, 1991

PRICE: \$14.00

WEYMOUTH TOWNSHIP MUNICIPAL UTILITIES AUTHORITY

ACKNOWLEDGEMENT OF PURCHASE OF

SEWER AND WATER CONNECTIONS

SERVICE APPLIED FOR: SEWER CONNECTION (): WATER CONNECTION ()

APPLICANT _____ DATE _____

BLOCK _____ LOT _____ STREET ADDRESS _____

NUMBER OF DCU'S _____

AWARD DATE _____ CONNECTION FEE _____

CONNECTION FEE PAYMENT DATE _____

YEARLY SERVICE CHARGE BEGINS _____

CONNECTION FEE PAYMENTS ARE NON-REFUNDABLE

CONNECTIONS ARE FOR THE DESIGNATED BLOCK AND LOT ONLY

DATE

AUTHORITY REPRESENTATIVE

WEYMOUTH TOWNSHIP MUA
EXTENSION STANDARDS

All residential, commercial, governmental, institutional, or industrial users in "The Village of Belcoville" shall be required to connect to the Weymouth Township Municipal Utilities Authority sewer and water system.

The cost of extension of a sanitary sewer main (8 inch in diameter or less) 200 feet or less shall be borne solely by the applicant.

The cost of extension of a water main (8 inch in diameter or less) 200 feet or less shall be borne solely by the applicant.

Extensions of the sanitary sewer system or water system in excess of 8 inch diameter or in excess of 200 feet shall be subject to the WTMUA recapture agreement.

Weymouth Township Municipal Utilities Authority
Amended Procedure for Connection to Water System

1) Definitions:

Individual: One domestic unit with existing water line along the street frontage of the lot.

Small User: One to three domestic units without an existing water line along the street frontage of the lots.

Major User: Greater than three (3) domestic units or commercial and industrial uses.

2) Fee Schedule

Individual	Unchanged
Small User	\$50 application fee Escrow \$100 minimum or 2% of applicant's engineers estimate
Major User	Unchanged

3) Application Procedure

Individual	Unchanged
Small User	Final application only
Major User	Preliminary and final applications, WTMUA may at their discretion review project in one phase depending on complexity of project.

Weymouth Township Municipal Utilities Authority
Amended Procedure for Connection to Sewer System

1) Definitions:

Individual: One domestic unit with existing sewer line along the street frontage of the lot.

Small User: One to three domestic units without an existing sewer line along the street frontage of the lots.

Major User: Greater than three (3) domestic units or commercial and industrial uses.

2) Fee Schedule

Individual	Unchanged
Small User	\$50 application fee Escrow \$100 minimum or 2% of applicant's engineers estimate
Major User	Unchanged

3) Application Procedure

Individual	Unchanged
Small User	Final application only
Major User	Preliminary and final applications, WTMUA may at their discretion review project in one phase depending on complexity of project.

Section 1.15E (Add) "or the first anniversary of receipt of the water connection, whichever comes first."

Section 2.8 (Delete) "If construction of the project is not started within two years from the date of the award of the connections to the applicant, all water connections and all applicable connection fees paid shall revert to the WTMUA."

Section 2.8 (Delete) "In the event that construction is commenced but within two years of the award the applicant has not used all connections, any unused connections shall revert to the WTMUA and the applicant shall receive a refund of the connection fees for the unused and rescinded connections."

Section 2.8 (Add) "All water connection fees are non-refundable. Water connections may not be transferred to other properties. The water service charge shall begin to accrue on the date the authority installs the water meter and turns on water flow to the property or the first anniversary of receipt of the water connection, whichever comes first."

Section 3.8 (Delete) "If construction of the project is not started within two years from the date of the award of the connections to the applicant all sewer connections and all applicable connection fees paid shall revert to the to WTMUA."

In the event that construction is commenced, but within two years of the date of the award the applicant has not used all connections, any unused connections shall revert to the WTMUA and the applicant shall receive a refund of the connection fees for the unused and rescinded connections"

Section 3.8 (Add) All sewer connection fees are non-refundable. Sewer connections may not be transferred to other properties. The sewer service charge shall begin to accrue on the date of the issuance of a certificate of occupancy for new units or the first anniversary of receipt of the water connection commitment whichever comes first."

ARTICLE VII

USER CHARGES

7.1 INTENT

Each user of the Local Sewer and/or Water System shall be assessed a user charge in such an amount as necessary and appropriate to defray the costs of constructing, operating and maintaining the Local Sewer and/or Water System and the annual charge imposed by the Atlantic County Utilities Authority for sewage treatment. The user charge system set forth below insures that each user will pay its proportionate share of construction, operation and maintenance costs incurred by the operation of the Local Authority.

Such user charges are based upon estimated annual operating and capital costs due to and owing by the Weymouth Township Municipal Utilities Authority (Local Authority) and may be changed from time to time as the need generated by such costs may require. For the first year of operation, the aforementioned estimates shall be based upon the costs incurred by the Local Authority for constructing, operating, and maintaining the existing sewer and water systems during the three (3) years preceding the enactment of Resolution 2-8-90.

7.2 DEDICATION OF ACCOUNT(S)

Revenues derived from the collection of user charges shall be deposited to and disbursements associated with the operation and maintenance of the Local Sewer and/or Water System shall be withdrawn from an account or accounts dedicated exclusively to these purposes.

7.3 SURPLUSES

When at the end of any fiscal year user charges have been collected in excess of those required to defray operating and maintenance expenses, the surplus may be applied to reduce user charges for the next fiscal year.

7.4 DETERMINATION OF USER CHARGES

7.4.1 Sewer Charges

Charges to residential and commercial customers of the Weymouth Township Municipal Utilities Authority are based upon a flat rate assessment. Each customer is charged in terms of equivalent domestic units defined as Domestic Consumer Units (DCU's). Each DCU is equivalent to 300 gallons per day (GPD) of sewage discharge. Charges to industrial customers will be determined on an individual basis. Users shall be classified and charged as follows:

1. Residential Users

Residential users shall be considered a user class and as such all users will be considered as having like wastewater quality. Charges to residential users shall be the charge for one (1) DCU per single family dwelling unit (i.e., single family home, apartment, etc.)

2. Commercial Users

Commercial users shall be considered a user class and as such all users will be considered as having like wastewater quality. Charges to commercial users shall be the charge per DCU times the number of equivalent DCU's for the commercial use as outlined in the Authority's "Schedule of Domestic Consumer Units for Sewerage Service."

3. Industrial Users

~~Industrial Users shall be considered a user class.~~ Charges to industrial users shall be based on the characteristics of each individual user. Rates shall be established by the quality-quantity base plus surcharge approach.

4. The annual fee per DCU shall be as set forth in the Authority's "Schedule of Rates."

7.4.2 Water Charges

Water charges for residential, commercial and industrial users shall be based on a flat rate assessment, plus a surcharge for usage over the quantity allowed by the flat

rate (overage). The flat rate and surcharge fees shall be as set forth in the Authority's "Schedule of Rates."

7.5 OTHER CHARGES AND FEES

No statement contained within this resolution shall be construed as prohibiting the collection of additional fees for initial sewer system collection, sewer expansions or extensions, dedicated (reserved) transport or treatment capacity in excess of current actual use or pretreatment of industrial wastes and/or water system distribution and water system expansions or extensions.

The additional fees and charges shall be as outlined in the Authority's "Schedule of Rates."

7.6 NOTIFICATION OF USER CHARGES

Each user shall, not less than once annually, be notified in writing of the computed user charge. The notification shall clearly identify the amount required for local sewage collection, the amount imposed for sewage treatment by the Atlantic County Sewerage Authority and the amount required for local water distribution.

7.7 PAYMENTS

All user charges herein prescribed shall be for the (calendar) year, (date) to (date) and shall be due and payable quarterly by the 15th day of the month following the end of the quarter.

7.8 UNPAID AMOUNTS

In the event of nonpayment of all or any portion of the user charges herein prescribed and provided as and when due, such unpaid amounts shall bear an interest penalty of the rate of 1.5% per month after fifteen (15) days from the date the amount became due.

7.9 REVISIONS TO USER CHARGES

The Local Authority shall, at least once annually, review, and, if necessary, revise this resolution and associated user charges to ensure that revenues are sufficient to offset the total costs of operating and maintaining the Local Sewer and Water System and maintain the proportionate distribution of costs among users or user classes.

ARTICLE VII

REVIEW OF USER CHARGE SYSTEM

The Weymouth Township Municipal Utilities Authority shall review the wastewater contributions and water usage patterns of users, the total costs of operation and maintenance and its approved user charge system not less than once per year. Upon review of its system, the WTMUA shall revise its charges to maintain the proportionate distribution of operation and maintenance costs to generate sufficient revenue to pay the total operation and maintenance costs.

The review of the user charge system will be based upon a detailed breakdown of expenses for operation and maintenance, such as labor, insurance, audit, normal repair, utilities, materials, replacement fund, contingency, debt service, etc.

Each user which discharges any toxic pollutants into the sewer system causing an increase in the cost of managing effluent or sludge shall pay for such increase in costs.

The cost operation and maintenance of the sewer system for all flow not directly attributable to users (i.e., infiltration/inflow) shall be distributed among all users by the same method that the cost of operation and maintenance is distributed among users.

ARTICLE IX

VALIDITY

All resolutions or parts of resolutions in conflict with this resolution are hereby repealed.

The invalidity of any section, clause, sentence or provision of this resolution shall not affect the validity of any other part of this resolution which can be given effect without such invalid part or parts.

May 21, 1987
Revised December 17, 1991

WEYMOUTH TOWNSHIP MUNICIPAL UTILITIES AUTHORITY
BELCOVILLE
MAYS LANDING, NEW JERSEY 08330

SCHEDULE OF DOMESTIC CONSUMER UNITS FOR SEWERAGE SERVICE

<u>Type of Structure</u>	<u>Domestic Consumer Units</u>
Single family homes	1 unit
Rented rooms, each room available for rent	¼ unit
Single family with place of business	1-½ units
Hotel or apartment house (for each living unit)	1 unit
Motel (for each living unit)	1 unit
Apartments (for each living unit)	1 unit
Schools (for each 30 pupils and faculty)	1 unit
Churches	1 unit
Clubs, Societies, Service Organizations (with bar and/or restaurant facilities 1 additional unit)	1 unit
Gymnasiums in schools, etc.	2 units
Public building (for each five (5) persons)	1 unit
Service stations without car wash facilities	2 units
Service station with car washing facilities	3 units
Diner, Tavern or Restaurant	
1 to 50 seating capacity	3 units
Each additional 15 seating capacity or segment thereof	1 unit
Soda fountain and or luncheonette	
First ten (10) seating capacity	1 unit
Each additional 20 seats or segment thereof	1 unit
Laundromat or self-service laundry	
For each washer of 12 lb. capacity	1 unit
For each washer of not more than 12 lb. capacity	½ unit
Supermarkets (for each 5 employees)	1 unit
Drive-in restaurants	
Seating capacity under 10	3 units
Seating capacity for additional 15 or fraction thereof	1 unit
Business establishment, not otherwise classified whether part of dwelling or not (each 15 employees or segment thereof)	1 unit
Amusement park	5 units
Public recreational facilities	5 units
Bakery (with baking facilities - whether part of dwelling or not)	2 units

For the purpose of planning, one domestic consumer unit is equivalent to 300 gallons per day.

The Authority will use one bill for all services. Billing will be on a quarterly basis.

TABLE OF CONTENTS

SECTION 1: RULES APPLICABLE TO BOTH WATER AND SEWERAGE SERVICE

	<u>Page</u>
1.0 DEFINITIONS	1
1.1 Application for Service	7
1.2 Renewal of Service	8
1.3 Owner and Tenant to Sign	8
1.4 Deposits	9
1.5 Timely Payments	9
1.6 Discontinuance of Service	10
1.7 Turn-off Without Authority	11
1.8 Due to Emergency	11
1.9 Reserve Supply	11
1.10 Renewal of Service After Discontinuance	11
1.11 Responsibility for Service	12
1.12 Bills and Payments	12
1.13 Continuing Obligation to Pay Sewer Service Charge	13
1.14 Mandatory Sewer and Water Connections	13
1.15 Commencement Date of Service Charges	13
1.16 Resolution In Effect	14
1.17 Unauthorized Connection to Sewer/Water System	14

SECTION 2: RULES AND REGULATIONS FOR THE CONSTRUCTION OF COMPREHENSIVE WATER SYSTEMS AND/OR MAIN EXTENSIONS

2.0 GENERAL PROVISIONS	15
2.1 Conditions Requiring the Installation of Water Systems and/or Main Extensions	15
2.2 Applications to the Authority	16
2.3 Application for Tentative Approval	16
2.4 Instructions for Application for Tentative Approval	16
2.5 Application for Final Approval	19
2.6 Instructions for Application for Final Approval	20
2.7 Inspection Fees	24
2.8 Application for Water Connection in Conjunction with Final Approval of Newly Constructed Water Facilities	24

2.9	Detailed Information on Design and Construction of Water Systems	
a.	Water system design criteria	25
b.	Construction of distribution system	28
c.	Construction of wells	31
d.	Construction of treatment plants	32
e.	Construction of booster pumping stations and storage tanks	33
f.	As-built Plans	33
2.10	Approval of Plans by State Agencies and Others	33
2.11	Inspection of Water System during the course of construction	34
2.12	Use of the Water System	36
2.13	Acceptance of Improvements by the Authority	37
2.14	Application for Connection to Existing Water System	37
2.15	Compliance with Rules and Regulations	38

SECTION 3: RULES AND REGULATIONS FOR THE CONSTRUCTION OF SANITARY SEWER EXTENSIONS, PUMPING STATIONS AND TREATMENT PLANTS

3.0	GENERAL PROVISIONS	39
3.1	Conditions Requiring the Installation of Sewerage Systems	39
3.2	Applications to the Authority	40
3.3	Application for Tentative Approval	40
3.4	Instructions for Application for Tentative Approval	40
3.5	Application for Final Approval	44
3.6	Instructions for Application for Final Approval	44
3.7	Inspection Fees	48
3.8	Application for a Sewer Connection in Conjunction with Final Approval of Newly Constructed Sewerage Facilities	48
3.9	Detailed Information on Design and Construction of Sewerage Systems	49
3.10	Approval of Plans by State Agencies, Atlantic County Sewerage Authority and Others	55
3.11	Inspection of Sewerage Systems During the Course of Construction	55
3.12	Use of the Sewer System	57
3.13	Acceptance of Improvements by the Authority	57
3.14	Application for Connection to Existing Sewerage System	58
3.15	Regulations Governing Wastes Discharged or to be Discharged into Sanitary Sewers	58
3.16	Compliance with Rules and Regulations	59

SECTION 4: RULES AND REGULATIONS FOR WATER SERVICE

4.0	WATER SERVICE CONNECTION	60
4.1	Size and Kind of Service Line	61
4.2	Separate Trench	61
4.3	Renewal of Service	61
4.4	Maintenance by Customer	62
4.5	Authority not Responsible	62
4.6	Property Supplies by Single Service Line	62
4.7	Single Service Line with Two or More Customers	63
4.8	Water Main or Service Line Crossing in Weymouth Township, Atlantic County and New Jersey State Roadways	63
4.9	Use of Water for Building Purposes	63
4.10	Water Meters	64
4.11	Public Fire Service	67
4.12	Private Fire Service	67

SECTION 5: RULES AND REGULATIONS FOR SANITARY SEWER SERVICE AND INDUSTRIAL WASTE DISCHARGE

5.0	SEWER SERVICE CONNECTION	69
5.1	Size and Kind of Service Lateral	70
5.2	Separate Trench	70
5.3	Renewal of Service Lateral	70
5.4	Maintenance by Customer	71
5.5	Authority Not Responsible	71
5.6	Property Served By Single Service Lateral	71
5.7	Single Service Lateral with Two or more Customers	71
5.8	Prohibited Connection	72
5.9	Special Connection	72
5.10	Special Precaution in Wet Ground	72
5.11	Industrial Wastes - Agreement Required	72
5.12	Special Application	73
5.13	Prohibited Wastes	73
5.14	Grease, Oil and Sand Separators	76
5.15	Preliminary Treatment	76
5.16	Penalty or Discontinuance	78
5.17	Industrial Waste Meters	79
5.18	Admission to Property	79
5.19	Protection from Accidental Discharge	79
5.20	Reporting of Accidental Discharge	79
5.21	Refusal of Discharge	80
5.22	Disputed Volumes and/or Pollutant Concentration	80

SECTION 6: INDUSTRIAL WASTE DISCHARGE PERMITS

6.0	WASTEWATER DISCHARGE PERMITS REQUIRED	81
6.1	Permit Application	81
6.2	Permit Conditions	82
6.3	Duration of Permits	82
6.4	Transfer of a Permit	83
6.5	Pretreatment Requirements	83

CONSTRUCTION DETAILS

APPLICATION FORMS

SECTION 1

RULES APPLICABLE TO BOTH WATER AND SEWERAGE SERVICE

1.0 DEFINITIONS

The following words contained herein shall have the following meanings:

- A. The word "Authority" shall mean the Weymouth Township Municipal Utilities Authority.
- B. The word "customer" or "owner" shall mean the applicant for water and/or sewerage service at one household or business, whether the owner or tenant, and who enters into an agreement therefor.
- C. The word "main" shall mean the authority owned or leased piping and appurtenances, in or along public highways and streets, or along privately owned right of way; used for the transmission and distribution of water to, or for the collection of domestic or industrial waste from its customers.
- D. "Domestic Sewerage" shall mean the normal water borne fluid wastes from residences, commercial establishments, institutions and industrial establishments limited to the wastes of kitchens, bathrooms, water closets, lavatories, and laundries.
- E. "Industrial Wastes" shall mean the liquid wastes from commercial or industrial processes as distinct from domestic sewerage.
- F. "Authority Engineer" shall mean a New Jersey Licensed Professional Engineer hired by the authority for engineering work.
- G. "Residential User" shall mean:
 - 1. Single family - a building on a lot designed or occupied exclusively as a residence for one family.
 - 2. Two family - a building on a lot designed and occupied exclusively as a residence for two families.

3. Multi family - a building on a lot or tract of land designed and occupied exclusively as a residence for three or more families whether through rental or fee simple arrangements.
 4. Boarding house, lodging house, nursing home, hotel, or motel. A dwelling having one kitchen and used for the purpose of providing lodging or both lodging and meals for pay or compensation of any kind whether computed by day, week or month, to persons occupying such dwellings other than members of a family.
- H. "Other than Residential User" shall mean all users other than residential, including but not limited to business, commercial, industry, restaurants, taverns, theaters, camps, churches, schools, hospitals; etc.
- I. "ACUA" shall be the Atlantic County Utilities Authority.
- J. "B.O.D." (denoting Biochemical Oxygen Demand) shall mean the quantity of oxygen utilized in the biochemical oxidation of organic matter or in satisfying the oxygen demand of other materials present during incubation for a given time at a specified temperature. It shall be reported as the amount of oxygen, expressed in milligrams per liter used in a period of five (5) days at twenty (20°C) degrees centigrade.
- K. "Chlorine Demand" expressed in milligrams per liter, shall mean the difference between the amount of chlorine added to wastewater and the amount of residual chlorine remaining at the end of twenty (20) minute contact period.
- L. "C.O.D." (denoting Chemical Oxygen Demand) shall mean the amount of oxygen required for the complete chemical oxidation of organics and oxidizable organics in a liquid.
- M. "Combined Waste" shall mean a wastewater containing surface or stormwater.
- N. "Compatible Pollutant" shall mean BOD, suspended solids, pH and fecal coliform bacteria, and such other additional pollutants as are now or may be in the future specified and controlled in the ACUA's NJPDES permit for its wastewater treatment plant where said plant has been designed and used to reduce or remove such pollutants.

- O. "Cooling Water" shall mean the water discharged from any system of condensation, air conditioning, cooling, refrigeration, or other sources. It shall contain no polluting substances which would produce BOD, SS or toxic substances as limited in Section 5 of these regulations.
- P. "Commercial User" shall mean any mercantile, establishment or place of business discharging less than 25,000 gallons per day of domestic sewerage or its equivalent to the (local) sewer system.
- Q. "County Sewer System" shall mean all intercepting sewers, pumping stations, force mains, wastewater treatment plants, and appurtenances thereto owned and operated by the Atlantic County Utilities Authority.
- R. "Effluent" shall mean wastewater after some degree of treatment, flowing out of any treatment device or facility.
- S. "Equivalent Dwelling Unit" (EDU) shall mean a dwelling or structure normally occupied by a single family.
- T. "Force Main" shall mean a pipe line carrying flow under pressure.
- U. "Grease or Oil" shall mean any material which is extractable from an acidified sample of a waste by hexane or other designated solvent;
- V. "Incompatible Pollutant" shall mean any pollutant which is not a compatible pollutant as defined in this Article.
- W. "Industrial Use" shall mean (i) any non-governmental, non-residential user of the Local Sewer System which discharges more than the equivalent of 25,000 gallons per day of domestic sewerage and which is identified in the Standard Industrial Classification Manual, 1972, Office of Management and Budget, as amended and supplemented under one of the following divisions:
1. Division A - Agriculture, Forestry and Fishing
 2. Division D - Mining
 3. Division D - Manufacturing
 4. Division E - Transportation, Communications, Electric, Gas and Sanitary Services.
 5. Division I - Services, or

- a. Any non-governmental user of the Local Sewer System which discharges wastewater containing incompatible pollutants subject to pretreatment standards, or
 - b. Any non-governmental user of the Local Sewer System which, discharges wastewater containing pollutants which would interfere with or prohibit the treatment and/or disposal of waste sludges.
- X. "Infiltration" shall mean water entering the Local Sewer System from the ground, through such means as, but not limited to, defective pipes, pipe joints, connections or manhole walls. Infiltration does not include, and is distinguished from, inflow.
- Y. "Inflow" shall mean water discharged into the Local Sewer System from such sources as, but not limited to, roof leaders, cellar, yard and area drains, foundation drains, cooling water discharges, drains from springs and swampy areas, manhole covers, cross connections from storm sewers and combined sewers, catch basins, storm waters, surface run off, street wash waters, or drainage. Inflow does not include, and is distinguished from, infiltration.
- Z. "Influent" shall mean wastewater, raw or partially treated, flowing into any wastewater treatment device or facilities.
- AA. "Intercepting Sewer," shall mean an ACUA-owned sewer which receives a flow from a local sewer system.
- BB. "Local Sewer" shall mean any sewer or system of sewers which receives flow from a local sewer.
- CC. "Local Sewer System" shall mean all intercepting sewers, force mains, pumping stations, and appurtenances thereto owned and operated by the Weymouth Township Municipal Utilities Authority.
- DD. "New Jersey Pollutant Discharge Elimination System" (NJPDDES) shall mean the program for issuing, conditioning and denying permits for the discharge of pollutants from point sources into the navigable waters, the continuous zone and the oceans pursuant to NJAC 7:14A.

- EE. "Person" shall mean any individual, firm, company, partnership, corporation, association, group or society, and includes the State of New Jersey, and agencies, districts, commissions and political subdivisions created by or pursuant to State Law.
- FF. "pH" shall mean the logarithm of the reciprocal of the hydrogen ion concentration.
- GG. "Pollutants" shall mean or may be so defined now or hereafter by appropriate local, state or federal agencies or by the ACUA, substances which may be present in wastewater, whether gaseous, liquid or solid, the amount of which, may contain soluble or insoluble solids of organic or inorganic nature which may deplete the dissolved oxygen content of natural waters, contribute solids, contain oil, grease, or floating solids which, may cause unsightly appearance on the surface of such waters, or contain materials detrimental to aquatic life.
- HH. "Premises" shall mean any parcel of real property including land, improvements or appurtenances, as buildings, ground, etc.
- II. "Pretreatment shall mean application of physical, chemical and biological processes to reduce the amount of pollutants in or alter the nature of the pollutant properties in a wastewater prior to discharging such wastewater into the County Sewer System.
- JJ. "Pretreatment Standards" shall mean all applicable federal rules and regulations implementing Section 307 of PL 92-500, as well as any non-conflicting state or local standards. In cases of conflicting standards or regulations, the more stringent thereof shall be applied.
- KK. "Pumping Station" shall mean a facility in which wastewater is conveyed from a lower hydraulic elevation to a higher hydraulic elevation using mechanical or pneumatic devices.
- LL. "Regulatory Agency", shall mean agencies, such as, but not limited to, the New Jersey Department of Environmental Protection, the United States Environmental Protection Agency and the U.S. Corps of Engineers which have authority over the operation of the Local Sewer System.

- MM. "Reserved Capacity" shall mean any portion of the County or Local Sewer System which has been exclusively reserved by and for a user through a formal, written agreement between the user and the Authority and the Atlantic County Utilities Authority.
- NN. "Sewer" shall mean a pipe or conduit, generally closed, for carrying wastewater.
- OO. "Shredded Garbage" shall mean garbage shredded to such a degree that all particles will be carried freely under the flow conditions normally prevailing in public sewers, with no particle having a dimension greater than 1/2 inch in any direction.
- PP. "S.S." (denoting Suspended Solids) shall mean the laboratory determination of the dry weight expressed in milligrams per liter of solids that either float on the surface, are in suspension or are settleable and can be removed from wastewater by filtering through a Gooch crucible.
- QQ. "Storm Water" shall mean the excess water running off from the surface of a drainage area or building during or immediately following a period of rain or snow melt.
- RR. "Superintendent" shall mean the Superintendent hired or appointed by the Authority or his duly appointed deputy, agent or representative.
- SS. "Toxic Substances" shall mean any substance whether gaseous, liquid or solid, which when discharged to the sewer system in sufficient quantities may tend to interfere with any treatment process, constitute a hazard to recreation in the receiving waters of the effluent from the wastewater treatment plant, pose a hazard to men working in the sewer system, or constitute a hazard to fish or animal life.
- TT. "Unshredded Garbage" shall mean solid waste from the preparation, cooking and dispensing of food or food products and from the handling, storing and sale of produce.
- UU. "User" shall mean any person discharging or permitting the discharge of wastewater to the Local Sewer System.

VV. "Wastewater" shall mean the water carried domestic, human or animal wastes from residences, building, industrial establishments or other places, together with such groundwater infiltration, industrial and commercial wastes as may be present.

1.1 Application for Service

- A. Water and sanitary sewer service connections will be considered upon written application signed by the property owner or his properly authorized agent. Water and sewer service will be considered only upon receipt of an executed contract by the property owner and tenant. Blank forms for all applications prepared for their respective services will be furnished by the Authority, and all applications must receive the approval of the Authority before connection is made, or either class of service is furnished.
- B. No application for service will be accepted by the Authority until the applicant has paid, or made satisfactory arrangements to pay all arrears and charges due by the applicant at any premises now or heretofore occupied by him.
- C. The accepted application shall constitute a contract between the Authority and the applicant, obliging the applicant to pay the Authority its rates as established from time to time to comply with its rules and regulations.
- D. Applications for service connections may be accepted subject to their being existing mains in streets or right-of-way abutting the premises to be served.
- E. When a prospective customer has made application for a new service, or has applied for the reinstatement of an existing service, it is assumed that the piping and fixtures on the applicant's premises are in good condition and the Authority will not be liable in any event, for any accident, breaks, or leakage arising in any way in connection with the supply of water or failure to supply same, or the freezing of water pipes or fixtures of the customer, nor for any damage to the property which may result from the usage of water supplied to the premises.

F. A new application may be made and approved by the Authority upon any change in ownership of the property when the owner is the customer or in any tenancy where the tenant is the customer, or in the service, as described in the application, and the Authority shall have the right upon five days notice, to discontinue the water supply until such new application has been made and approved. Although property may have been occupied or leased to a tenant and the tenant may have paid the water or sewer bills, the owner of the property is responsible for the payment of any water and sewer bills not paid by the tenant.

G. Industrial and commercial establishments making application for water and/or sanitary sewerage service, in addition to making written application for such services, shall furnish a detailed description of the type and size of buildings, the nature of businesses to be conducted in each structure, the number and type of fixtures to be served, the type, volume and chemical characteristics of wastes to be discharged. Such applicants shall also furnish to the Authority four copies of the plan showing:

1. The boundaries of the property.
2. The location within the property of the structures to be served.
3. The location of and profile, with respect to the finished grade, of the services.
4. Details of the proposed connections to the water and sewerage systems, and arrangements and details of meter installation. (Refer to rule 5.12, with respect to the admissibility of industrial wastes.)

1.2 Renewal of Service

Water service will be renewed under proper application, when the conditions under which such service was disconnected are corrected, and upon the payment of all charges provided in the schedule of rates, or rules of the Authority.

1.3 Owner and Tenant to Sign

Where a water and/or sanitary sewer connection has been previously installed and service is desired, a proper application shall be signed by the owner and tenant.

1.4 Deposits

- A. The sum of \$125.00 for domestic house water meters may be required as security from the homeowner at the time of installation or commencement of service and shall be repaid at final settlement. Bills meanwhile are to be paid regularly or as rendered.
- B. Deposits for commercial and industrial meters may also be required, in a sum to be established by the Authority Engineer, at the time of installation and in keeping with the appropriate replacement value of the size and type of meter installed. The security shall be repaid at final settlement. Bills meanwhile are to be paid regularly or as rendered.
- C. Deposits may be required from customers taking service for a period of less than 30 days, in an amount equal to the estimated gross bill for such temporary period, plus the cost of establishing and discontinuing such service. Deposits may be required from any other customer who becomes habitually delinquent, provided that in no instance will such deposits be required in excess of the lesser of 1) the estimated gross bill for any single billing period plus one month; or 2) \$100.00.
- D. Any customer having paid a deposit shall pay bills for water and sewer service as rendered, in accordance with the rules of the Authority. The deposit shall not be considered as payment on account of a bill during the time the customer is receiving service.
- E. Deposits shall be returned to the depositor when he or she shall have paid undisputed bills for service for a period of 12 consecutive months; and any customer having secured the return of deposit will not be required to make a new deposit unless the service has been discontinued and the customer's credit standing impaired through the failure to comply with the Authority's rules.
- F. No interest will be paid on deposits.

1.5 Timely Payments

Timely payments of any bill for service, within the meaning of these rules shall be:

- A. Payment of the bill with or without penalty, within 15 days following the period for which the bill was rendered;
or

- B. Payment within 30 days following the presentation of the bill; or
- C. In the case of disputed bills for which payment is withheld beyond the period herein mentioned, no later than 10 days following the termination of the dispute, but only if the dispute is terminated substantially in favor of the customer.

1.6 Discontinuance of Service

- A. Customer. All agreements covering water supply and/or sanitary sewerage service shall continue in force, unless and until receipt of reasonable notice in writing of a desire to terminate the contract. Water service only to any premises will be terminated upon the written order of the applicant, without in any way affecting the existing agreement for sanitary sewerage service. (see Section 5.0 for sanitary sewer service).
- B. The Authority. Service may in the sole discretion of the Authority, be discontinued for any of the following reasons:
 - 1. Misrepresentation in application.
 - 2. Willful waste of water through improper or imperfect pipes, fixtures, or otherwise.
 - 3. Failure to comply with the constrictions imposed pursuant to section.
 - 4. Use of water for any other property or purpose than that described in the application.
 - 5. Molesting any service pipe, meter, curb stop cock or seals or any other appliance of the Authority.
 - 6. Vacancy in excess of 30 days (water only).
 - 7. Neglecting to make a renewed deposit, for any nonpayment of any charge accruing under the application.
 - 8. Refusal of any reasonable access to the property for the purposes of inspecting or for reading, caring for, or removing meters.

9. Making, or refusing to sever any cross connection between a pipe or fixture carrying water furnished by the Authority and a pipe or fixture carrying water from any other source.
10. Nonpayment of bills within the time prescribed by Subsection 1.5.
11. Violation of any of the rules of the Authority.

1.7 Turn Off Without Authority

Neither the customer or any plumber or any other person shall turn the water on or off at any corporation stop, curb stop or water valve; or disconnect or remove the meter or permit its disconnection or removal, without the written consent of the Authority.

1.8 Due to Emergency

As necessity may arise in the event of breakdown emergency, or for any other unavoidable cause, the Authority shall have the right to cut off the water supply temporarily, in order to make the necessary repairs, connections, etc. but the Authority will use all reasonable and practicable measure to notify the customer of such discontinuance of service. In such case, the Authority shall not be liable for any damage or inconvenience experienced by the customer; or any claim against it at any time for interruption in service, lessening of the supply in adequate pressure, poor quality of water, or for any causes beyond its control. When the supply of water is to be temporarily interrupted, notice will be given, when practicable, to all customers affected by the temporary interruption of the service, stating the probable duration of the interruption, and also the purpose of the interruption.

1.9 Reserve Supply

The Authority shall have the right to reserve a sufficient supply of water at all times in storage, to provide for fire and other emergencies or may restrict or regulate the quantity of water used by the customer in case of scarcity or whenever the public welfare may so require.

1.10 Renewal of Service After Discontinuance

Water service will be renewed, under proper application, when the conditions under which such service was discontinued have been corrected and upon the payment of all proper charges or amounts provided in the schedule of rates or rules of the Authority, due from the applicant.

1.11 Responsibility for Service

It is agreed by the parties receiving public fire service, private fire service, or any service, that the Authority does not assume any liability as insurer of property or person and that the Authority does not guarantee any special service, pressure, capacity, or facility, other than is permitted by the ordinary and changing operating conditions of the Authority as the same exists from day to day. It is agreed, by the parties receiving service, that the Authority shall be free and exempt from any and all claims for injury due to any persons or property by reasons of fire, water, failure to supply water pressure or capacity.

1.12 Bills and Payment

- A. Bills are payable at the office of the Hamilton Township Municipal Utilities Authority, Oak and Hanthorn Streets, Mays Landing, New Jersey, as the Authorized Collection Agent for the Weymouth Township Municipal Utilities Authority.
- B. Regular water meter readings will be made quarterly and bills for service will be rendered as soon as practicable after the reading of the respective meters. In the case of fire service, bills will be rendered on or about the first days of February, May, August, and November, for service during the preceding three months. All bills are due and payable on presentation or delivery. All customers connected to the water system will be billed and shall pay the minimum charge quarterly.
- C. If a bill remains unpaid for a period of 15 days after presentation, it shall be classified as delinquent. Payments made by mail will be credited as received on the date of mailing as evidence by the U.S. Post Office cancellation stamp. If a bill remains unpaid 14 days after being classified as delinquent, service may be discontinued on not less than 5 days notice. If service is thus discontinued, it will not be restored until all unpaid bills and all charges, including the turn on charge, are paid, or satisfactory arrangements are made for payment. Interest rates to be set by the Authority but not to exceed the statutory rate per month on the unpaid balance will be made on delinquent bills. Any unpaid balance of any service charge and interest thereon shall be a lien on the parcel of real property with respect to the service which was rendered with the affect and pursuant to the procedure specified under N.J.S.A. 40:14B-42. Notice of delinquent charges shall be given monthly by the Authority to the collector of taxes of the Township of Weymouth.

1.13 Continuing Obligation to Pay Water & Sewer Service Charge

Upon connection of an approved and usable property to a water main or sanitary sewer, the obligation to pay the minimum annual service charge continues despite the failure to occupy the property, or to use the water or sewer facilities, so long as the building or structure on the property is still available for use and the sewer facilities remain available.

1.14 Mandatory Sewer and Water Connections

Whenever the facilities of a sanitary sewerage collection system or water distribution system shall be available in any given area of Weymouth Township, the owner of any property which abuts the root of said sewerage and/or water system facility shall, prior to or as a condition of continued occupancy be required to tie into said system, make use thereof and be subject to the cost charges as shall be promulgated from time to time by the Authority pursuant to statutory authorization.

Additionally any facility, whether new or existing, located within 200 feet of a watermain or sanitary sewer main, shall be required to apply for the appropriate service(s) and to physically connect to said water or sewer main upon approval by the Authority. At the time approval is granted, the owner shall pay all applicable connection fees as shown in the current schedule of rates and charges.

1.15 Commencement Date of Service Charges

Unless the Authority shall determine otherwise in unusual cases, service charges for both water and sewer service for existing structures shall begin to accrue on the earlier of the following dates:

- A. The date of the actual connection of the premises to the water and sewer system.
- B. Thirty (30) days after the issuance of a connection permit.
- C. The last date for mandatory connection to water or sewer system in accordance with subsection 1.15.
- D. With respect to future construction, sewer service charges shall begin to accrue on the date of the issuance of a certificate of occupancy for such new units or the first anniversary of receipt of sewer connection commitment, whichever comes first.
- E. With respect to future construction, water service charges shall begin to accrue on the date the Authority installs the water meter and turns on water flow to property, which date shall precede issuance of the certificate of occupancy.

1.16 Resolution in Effect

This resolution shall take effect immediately, and a copy shall at all times be kept on file at the offices of the Weymouth Township Municipal Building, Dorothy, New Jersey and shall at all reasonable times be open to public inspection.

All resolutions, rules or regulations inconsistent herewith are hereby rescinded.

The Authority shall as it deems necessary amend these Rules and Regulations by passage of an amending resolution at a duly authorized meeting of the Authority.

1.17 Unauthorized Connection to Sewer/Water System

Any property owner or person(s) authorizing a contractor to connect water or sewer services to a property without the permission of the Weymouth Township Municipal Utilities Authority is subject to legal recourse by the Authority. Prior to the granting of said permission, all connection and lateral fees must be paid.

SECTION 2

RULES AND REGULATIONS FOR THE CONSTRUCTION OF COMPREHENSIVE WATER SYSTEMS AND/OR MAIN EXTENSIONS

2.0 GENERAL PROVISIONS

The policy of the Authority shall be to make no future extensions to the system unless paid for those requesting the same. No facilities for the treatment of water within the Township shall be constructed unless the Authority shall give consent to the Authority Engineer who shall approve plans and specifications therefor. Accordingly, as subsequent construction of water facilities are to be consented to and approved by the Authority, the Authority plans to encourage connection to its system whenever possible and practicable so as to secure an adequate supply of water. Water lines needed for any future connections, together with related appurtenances shall be installed by those requesting the service. All water mains and appurtenances including valves, fittings, and hydrants, whether installed by the Weymouth Township Municipal Utilities Authority or not shall be owned and maintained by the Authority, when located in dedicated municipal streets or right-of-ways.

Ownership and maintenance of facilities installed other than in dedicated municipal streets or rights-of-way may be assumed by the Authority at its discretion. If the Authority does not assume ownership and maintenance of said facilities, then a private organization shall be established (i.e. homeowners association, condominium association, etc.) to assume ownership and maintenance of the facilities. The documents creating this organization and defining its responsibilities shall be subject to review by this Authority.

It shall further be the policy of the Authority to charge connection fees for the privilege of connection to its water system in accordance with the schedule of rates.

2.1 Conditions Requiring the Installation of Water Systems and/or Main Extensions

Any major subdivisions or any multi-family structure, regardless of volume of use, and all non residential development such as schools, commercial buildings, industrial buildings and all other structures shall be required to install a water system and appurtenances to connect with the nearest existing water main in the Township, in accordance with the provisions of these rules and regulations except as herein provided.

In the event that the applicant's plans are deemed by the Authority to be too remote from an existing water main, then a well, treatment plant for the treatment of water and storage facilities may be required. Said plant and the location thereof to be subject to the approval by the Authority in accordance with the standards and requirements as hereinafter set forth, and as may be required by other governmental regulatory agencies.

Any common facilities installed under the provisions of this section shall be transferred to the Authority as hereinafter described.

2.2 Applications to the Authority

Prior to consideration, applications shall be filed with the Authority together with the required fees.

All tentative and final applications must be submitted at least 15 days before a regular scheduled meeting of the Authority. All applications are to be signed by the Owner or by an authorized agent or representative and if signed by an authorized agent, shall be accompanied by proof of authorization by affidavit.

2.3 Application for Tentative Approval

The applicant shall submit a tentative application in duplicate, on a form provided by the Authority.

2.4 Instructions for Application for Tentative Approval

- A. A non-refundable application fee of \$20/unit, minimum of \$50.00, shall be submitted with the application
- B. A fee of 2% of the estimated cost of construction (minimum \$1,000.00) as determined by the Applicant's Engineer, subject to the review and approval of the Authority's Engineer, shall be submitted with the application. Said fee shall be deposited in an escrow account to cover the cost of review of the project. The escrow account shall be replenished from time to time as deemed necessary by the Authority.
- C. The application shall be accompanied by the following supporting data:
 1. Engineer's Report.
 2. General Map of the entire project, 7 copies.
 3. Plans of all proposed water mains, including service connections to all property lines, and hydrants, 7 copies.

4. General plan for booster pumping stations, treatment plants, and/or water tanks.

D. Data shall contain information described below:

1. Engineer's Report

- a. A complete engineer's report setting forth the basis of design shall be submitted to the Authority for each project.
- b. All water mains shall be designed to carry the peak hour flows, and where fire protection is provided, the required fire demand plus the required domestic demand. The average daily consumption shall be assumed to be 100 gallons per capita per day, and each unit to be occupied by four persons.
- c. Material specifications and construction details shall be set forth and comply with those specified under "Detailed Information on Design and Construction of Water Systems".

2. General Map of the Entire Project

A general map of the entire project shall be furnished to show water distribution system booster pumping stations and water supply and storage facilities, for the whole area at a scale of 1" = 200' and a key map at a scale of 1" = 2000'.

3. Plans of all Proposed Water Mains

Properly entitled plans shall be of uniform size, 24 x 36 inches or 30 x 42 inches, with a 1/2 inch border on top, bottom, and right side and a 2-inch border on the left side. Seven sets of plans shall be submitted and show the following:

- a. Details - Plans shall show all existing and proposed improvements including underground utilities, water mains, sewer mains, storm drains, etc. Contours will be shown at 2 foot intervals with proposed streets and surface elevations at all breaks in grade and street intersections, tributary areas with population per acre, the true or magnetic meridian, boundary line, title, date and scale.

All sheets shall be numbered. Drawings not meeting reasonable engineering standards as to accuracy and neatness will not be accepted.

- b. Symbols - Watermains proposed under the application shall be shown by a solid line (—W—); existing watermains shall be shown by a dashed line (--W--).

All other appurtenance symbols shall be shown in accordance with the recommended practice of the American Water Works Association (AWWA).

A legend shall be provided on all plans defining the symbols as shown on the plan.

- c. Elevations - All permanent bench marks of U.S. Coast and Geodetic Survey shall be shown. Sufficient bench marks shall be permanently established for the area, and shall be set at all supply, treatment, and storage facilities sites.

- d. Distances, Grades and Sizes - The distances and stationing between valves, depth of cover, water main sizes, strength class, and material shall be shown on the plans. Arrows shall show the general direction of the flow. Plans, profiles and hydraulic analyses of the existing

water distribution system from the applicant's point of connection to the point of supply by the Weymouth Township Municipal Utilities Authority shall be included.

4. General Plans for Water Supply and Storage Facilities

The plans for the water supply and storage facilities shall include a general site plan showing boundaries, one-foot contours, proposed wells, pumping stations and/or treatment plants, storage facilities with capacities, underground piping, underground or overhead wires.

- D. The following will govern the approximate sizes and locations of mains, points or connections, wells and storage facilities:

If the size of any water main, as shown by the application is inconsistent with the requirements of the area, the applicant shall install mains, as required by the Authority.

If the Authority requires the installation of facilities (booster pumping stations, storage facilities, and treatment plants) of greater capacity than that determined by the Authority as necessary to serve the applicant; the Authority shall pay said applicant the difference between the cost of the facilities necessary to serve the applicant and the cost of the facilities required by the Authority.

The Authority will not assess the increased cost, if any, of the Engineer's review and inspection fee when the increased cost of construction results from an order by the Authority.

Individual service connections for each property will be furnished by the applicant.

2.5 Application for Final Approval

Upon notification by the Authority that tentative approval has been granted, an application for final approval may be filed in duplicate on a form provided by the Authority.

2.6 Instructions for Application for Final Approval

- A. A fee of 2% of the estimated costs of construction as determined by the Applicant's Engineer subject to the review and approval of the Authority's Engineer, shall be submitted with the application. Said fee shall be deposited in an escrow account to cover the cost of review of the project. The escrow account shall be replenished from time to time as deemed necessary by the Authority.

The application shall be accompanied by the following supporting data:

1. Details of construction and distribution system and appurtenances, 7 copies.
2. Detailed plans of wells, pumping stations and/or treatment works, if applicable, 7 copies.
3. Detailed plans of all storage facilities, 7 copies.
4. Specifications for the construction of proposed water system and appurtenances including pumping stations and/or treatment plants, also method of disinfection, 7 copies.
5. Detailed estimate of entire construction cost, 7 copies.
6. Performance bond.
7. Seven copies of the Engineer's report, together with other data furnished with the application for tentative approval, if requested by the Authority.
8. Proof of title to all lands and copy of proposed conveyances and easements.
9. An application form, to the New Jersey State Department of Environmental Protection.

B. Data shall contain information described below:

1. Plans and Details of Construction of Distribution System and Appurtenances - Overall plans shall give a complete picture of the systems proposed and area primarily intended to facilitate review. The Engineer for the Developer shall show all design information on the overall plan. No restriction shall be placed on the size or scale of the overall plan except that all information shown shall be clear and legible. The detail drawings shall be legible and to a scale not less than 1" = 100' horizontal. They shall show roads, curbs, sidewalks, lot lines, boundary lines, and typical street cross-sections in addition to all the items listed below: Details of the unusual conditions to be encountered in the construction of the distribution system along with hydrant details, thrust block design, blow-off, and air release valves. A title and index sheet shall accompany the plan and detail drawings and shall include a key map of the subdivision and its relationship to the surrounding area. All drawings with the exception of the overall plans shall be of uniform size 24 x 36 inches or 30 x 42 inches with a 2-inch border on the left side and a 1/2-inch border on all other sides. The overall plan of the water system shall be entitled "Overall Plan Water System". It shall show the location of the wells, treatment plants, storage tanks, pressure zones, valves, distribution lines, hydrants, and the present and future extent of the distribution system. Size, type, and class pipe shall be given. Also shown shall be the permanent bench marks, contours of existing ground referenced to U.S. Coast and Geodetic Survey datum. All sheets shall be numbered and bound and shall show the true and magnetic meridian, title, date, and scale including topographical symbols. Conventions and elevations shall be the same as or based upon those used by the U.S. Coast and Geodetic Survey.

2. Detailed Plans of Wells, Pumping Stations and/or Treatment Works - The plans for the wells, pumping stations, and/or treatment plants, shall include general site plan showing boundaries, one-foot contours, proposed pumping stations, wells, underground piping and appurtenances, underground and overhead wires. The detail plans for wells shall show the depth, size and construction of each well. Results from test wells, logging, etc. shall be furnished as the basis for design. The ground strata through which the well is to be driven shall be shown in cross-section. The arrangement of mechanical and electrical equipment within the well house plus connections to the storage tanks and distribution system shall be shown. The method and equipment proposed for applying chlorine shall be clearly indicated. If treatment beyond chlorination is required, the plans shall show details of each component of the treatment facility, the method of applying chemicals, master meter, piping, valves, etc. The plans and specifications must indicate provisions for landscaping, paved roads, and walkways. Drawings shall conform to the size specified with these rules and regulations.
3. Detailed Plans of Storage Facilities - Storage may consist of an elevated tank, standpipe or, where units do not exceed 50, hydro pneumatic tank, may be constructed of either steel or reinforced concrete. The details of all storage facilities shall include tank dimensions, minimum water level and overflow level, capacity, foundation, piping, valve pit dimensions, etc.
4. Specifications - Complete specifications for the construction of the proposed water system and appurtenances, including pumping stations and/or treatment plants, method of disinfection, shall accompany the plans. They may be omitted for main extensions, provided specifications for the water system are already filed and reference is made to them in the application. In addition, the requirements of all governmental regulatory agencies must be satisfied by the submitted specifications.

5. Estimate of Costs - An itemized list of improvements to be constructed shall be furnished and shall include cost of rights-of-way and easements as may be required. The estimate of costs will be subject to review and approval of the Authority engineer.
6. Performance Bond - A Performance Bond in a form approved by the Authority and the Authority's Attorney in an amount of 100% of the total construction cost as defined in "Estimate of Costs", guaranteeing complete construction within the time period to be specified by the Authority, and further guaranteeing that said construction will be in accordance with the Rules and Regulations of the Authority, the plans and specifications, engineer's report, and the cost estimates as approved by the Authority and to the satisfaction of the Authority's Engineer.
7. Engineer's Report - The engineer's report shall include but not be limited to, all information required by the New Jersey Department of Environmental Protection and other regulatory agencies.
8. Proof of Title - A copy of a title report, title policy or attorney certificate, establishing that no part of the system is encumbered so as to prevent, unduly restrict, or circumscribe the ability of the applicant to make all conveyances, transfers and dedications incidental to vesting in the Authority, title to the entire system and its appurtenances together with copies of all proposed documents to effect such conveyances, transfers and dedications.
9. Application to the New Jersey Department of Environmental Protection - The applicant shall as a condition to receipt of final approval by the Authority, prepare and submit to the New Jersey Department of Environmental Protection, all required plans and specifications, Engineer's Report and the New Jersey DEP form in duplicate. The applicant shall submit the entire exhibit to the New Jersey Department of Environmental Protection in the name of the Authority, when the Authority agrees to accept ownership and maintenance of the proposed facilities.

Should the Authority decide not to accept ownership and maintenance of the proposed facilities, applicant shall process an application in its name, said application package subject to review and approval by the Authority.

Prior to endorsement of the application package by the Authority, the applicant shall post the Performance Guarantee with the Authority.

2.7 Inspection Fees

The applicant shall pay an inspection fee to the Authority in addition to the application fee based on the said estimate of costs. Payment of the inspection fees shall be made in the following manner. As a condition of final approval and prior to commencing actual construction, the applicant shall deposit with the Authority 6 1/2% of the said estimate of costs.

Final approval shall expire 2 years from the date approval is granted.

2.8 Application for Water Connection in Conjunction with Final Approval of Newly Constructed Water Facilities

This application shall be filed in duplicate on a form provided by the Authority. The applicant shall pay a connection fee, as provided in the current schedule of rates and charges adopted by the Authority, which shall be paid to the Authority upon submission of an application for connection.

Water connections will be awarded after final approval has been granted. The applicant shall pay the connection fees within 30 days from the date of the award of the connections, but in no case shall the Authority provide the necessary state endorsements prior to the payment of the connection fees.

If the construction of the project is not started within two years from the date of the award of the connections to the applicant, all water connections and all applicable connection fees paid shall revert to the WTMUA.

In the event that construction is commenced but within two years of the date of the award the applicant has not used all connections, any unused connections shall revert to the WTMUA and the applicant shall receive a refund of the connection fees for the unused and rescinded connections.

Should a portion of the applicant's property front on a previously existing water main, an application for water connection shall be filed with the Authority. This application shall be accompanied by fees set forth therein on a form provided by the Authority.

Water connections shall be made to a water main only under the review and inspection of the Authority's authorized representative. Connection to the water main shall be made in accordance with the method set forth within these Rules and Regulations.

A water service connection shall be defined as the pipe and appurtenances, as set forth below, between the Authority's water main and the individual property line.

Water pipe from the property line to the building is under the jurisdiction of the Board of Health or the local construction code official through its plumbing inspector and his approval will be required before the Authority will permit usage of the facility.

The above shall also apply where a landowner is required by the Authority to connect to an existing water main.

The landowner is solely responsible for the maintenance and/or repair of the water pipe between the building and the Authority's shut-off.

2.9 Detailed Information on Design and Construction of Water Systems

A. Water System Design Criteria

1. General

The following requirements are to be considered minimum requirements for the design and construction of water system. The Applicant shall, through the proper balance of supply, storage and distribution, secure for the community a water system comparable to an "F Rating System" as judged by the Insurance Services Office and outlined in their Standard Schedule for Grading Cities and Towns.

Regardless of the size of the development, the distribution system shall be capable of supplying the necessary domestic flow and fire protection based upon the complete development flow and fire requirements.

2. Distribution System and Appurtenances

In the design of the water distribution system a C=100 frictional index based on the Hazen & Williams formula shall be used.

Hydrants shall be located within a 600 foot radius of each other or shall provide a maximum hoselay of 800 feet. Air release valves shall be provided at all high points in the system. Fire hydrants shall be placed at all water main dead ends longer than 400 feet, otherwise an approved blow-off shall be provided for flushing purposes.

The design of the distribution system shall be based upon the required maximum daily demand flow plus the fire demand, or peak daily demand, whichever is greater, in all areas. The minimum size of water mains shall be 6 inches. The Hardy Cross method or an equivalent method shall be used in balancing loops. Minimum depth of cover shall be 4 feet from the top of the pipe to the finished grade. Distribution mains shall be inter-connected when possible into closed loops so that the supply may be brought to the consumer from more than one direction. Dead end streets shall be provided with looped water mains wherever practical or feasible. All dead-end lines not so looped and less than 400 feet in length shall be provided with a means of flushing. Valves of full line size shall be installed at ends of all dead-end lines which may be extended in the future.

Valves shall be located on distribution mains so that not more than one block shall be out of service for one single break, if possible. At street intersections, valves shall be located in line with property lines for ease in finding in the event of a break. Geared valves on 16 inch mains or larger shall be furnished and so indicated on the plans.

A corporation stop with a valve box for air release shall be located at all high points in a distribution system, with adequate means of drainage provided.

Unrestricted easements to the Authority water mains shall be a minimum of 20 feet wide. The pipe shall be placed 5 feet off either easement line to allow sufficient room for maintenance or installation of future pipe.

3. Storage Tanks

Storage in elevated tanks or standpipes shall have a total effective capacity, which when combined with pumping capacity, shall be at least equal to the fire demand flow plus the maximum day consumption, or meet the peak hour demand requirements, whichever is greater.

The water levels in all elevated storage shall be 70 feet higher than the highest point in the area being served, with allowance made for building heights.

The pumping equipment, when hydro-pneumatic tanks are used, shall be designed to facilitate its change over to the overall elevated storage system as required by the Authority without undue loss in pressure in any part of the system.

A double acting altitude valve shall be used for water level control in elevated storage tanks and standpipes. A by-pass line and pit shall also be provided.

The capacity of hydro-pneumatic tanks shall be sufficient to provide the peak hourly rate of consumption in combination with the pumping facilities for a period of not less than 20 minutes. The effective capacity of the tank shall be taken at 25%. The following formula shall govern the size of hydro-pneumatic tanks:

Required tank capacity in gallons = (Peak flow less well yield) x 20 x 4.

Peak hourly flow rate and total allowable yield from wells shall be expressed in gallons per minute.

4. Water Supply

The average daily, maximum daily, and peak hourly water demand rates for commercial, industrial and institutional areas shall be considered separately in the computation of the total system demand and the quantities to be added shall be determined by the Developer and approved by the Authority. Maximum daily flow shall be considered as 2.5 times average daily flow. Peak hourly flow shall be considered as 4.0 times average hourly flow.

Fire protection shall be furnished for any development numbering 50 or more units. In that event, the Developer shall provide fire flows in addition to the maximum daily requirements based upon 250 gallons per capita. Fire flow rates established by using formulas currently in use by the Insurance Services Office shall determine the flow rates required in any development or portion thereof. The formulas shall be used for high value districts, single family, attached and multiple family districts. Fire flow for each district shall be computed separately. The minimum allowable fire flow shall be 600 GPM. The system shall be capable of supplying particular fire flow requirements in any part of the system during the maximum day as determined in the ISO schedule for Grading Cities and Towns.

In the event that the design peak hour demand flow rate exceeds the maximum day consumption plus the fire flow rate required above, the system shall be designed for the greater rate.

5. Treatment Requirements

Treatment facilities shall be so designed to produce water after treatment that is reasonably uniform and of the following quality:

<u>Characteristic</u>	<u>Maximum Permissible Concentration in ppm</u>
Iron & Maganese	0.3
Hardness	100.0
Chlorides	250.0
pH	7.2 to 9.0
Taste & Odor	None
Sulphate	250
Turbidity	3 units
Color	15 units

B. Construction of Distribution System

1. Pipe Materials

Pipe materials to be used in construction of water mains shall be ductile iron.

For bridge crossings, or other special aerial installations, pipe material shall be steel, or ductile iron pipe.

Ductile iron pipe shall conform to ANSI Specification A-21.51 (latest edition) standards for water and other liquids. Wall thickness of pipe shall be determined in accordance with ANSI Specification A-21.50 (latest edition) but in no case shall the wall thickness be less than that specified for Class 50 pipe.

Ductile iron pipe shall have an interior cement mortar lining in accordance with ANSI Specification A-21.4 (latest edition).

Suitable adapters to flanged fittings shall be finished where required.

Steel pipe shall conform to AWWA C202. Steel pipe under 12 inches in diameter shall be Schedule 40, 12 inches and over shall have a wall thickness of 0.375 inches. Steel pipe shall be cement mortar lined and coated in accordance with AWWA C104. Buried steel pipe shall be primed (2 mil. dry) and painted, 2 coat vinyl (3 mil. dry, total).

2. Valves

Gate valves shall be cast iron body with double disc gates, bronze mounted. Valves shall be full size. Valves on 16-inch mains or larger shall be geared and shall have suitable by-passes.

Valve boxes shall be of the adjustable type, with cover indicator of "water" and direction of valve operation.

3. Hydrants

Fire hydrants shall have a minimum valve opening of 4 1/2 inches. Unless otherwise directed by the Authority, hydrants shall have one 4 1/2 inch connection for fire engine pumps and two 2 1/2 inch connections for direct hose connection. All hose connections shall have National Standard Threads.

All fire hydrants shall be painted yellow. All fire hydrants shall be Mueller Modern Improved or approved equal.

All hydrants shall be connected to the main line with pipe not less than 6 inches in diameter. A gate valve and box shall be located between the hydrant and the main.

4. Fittings

All fittings shall be new and suitable for a minimum working pressure of 150 psi, and shall meet the requirements of ANSI/AWWA C110 (latest edition).

Iron fittings shall be cement lined with a bituminous seal coat interior conforming to ANSI A 21.4 and an exterior coating of coal tar or asphalt foundary dip.

All dead ends on mains shall be valved and closed with iron plugs or caps. Tees, bends, etc. of 11-1/4° or greater shall be blocked against movement from water pressure.

5. House Service Connections

A house service connection shall be defined as the pipe and appurtenances between the Authority's street main and the individual property line. A house service connection shall be made as provided herein. (see Subsection 4.2).

Where comprehensive water systems are constructed, meters may be furnished and installed by the Applicant which shall be of a manufacture and type approved by the Authority. In all other cases, the applicant shall pay meter fees and install at his expense meters furnished by the Authority.

Meters shall read in "gallons".

Meter location shall be standardized by each developer, wherever possible.

6. Water Meter Requirements for Builder/Developer

For all intents and purposes, a builder/developer is one who engages in the construction of any project other than one single family dwelling at any given time.

The Authority Engineer will review all comprehensive water distribution plans for any subdivision or development. Responsibility for the cost of all appurtenances involved in the metering of the project will be borne by the Developer.

The Authority Engineer will review all comprehensive water distribution plans for any subdivision or development. Responsibility for the cost of all appurtenances involved in the metering of the project will be borne by the developer.

Recommendations will be made by the Authority Engineer as to the most efficient and effective method of metering the particular project under his review. All costs for meters and related parts will be paid by the developer in addition to the established connection fee. No certificate of occupancy will be issued until the complex is metered and all fees applicable have been paid.

C. Construction of Wells

Wells shall be constructed and protected against possible contamination in accordance with American Water Works Association Standard A100. Well casings should be welded and made up with threaded couplings, and the protective casing shall have tight joints throughout its entire length.

A gamma ray log and/or a caliper log shall be provided for each well. The flow from each well shall be averaged over a 48-hour period and shall not be less than 300 gpm with a drawdown not lower than 5 feet above the top of the screen or pump, whichever is higher. Static readings of the well shall be taken every 3 hours for 12 hours prior to starting the tests. During the test, one hour will be permitted for adjustment of equipment during each 8-hour period except that the pumping shall be continuous during the final 8 hours.

Test water level readings shall be taken at the following time intervals:

- 6 readings every 5 minutes for 30 minutes
- 3 readings every 10 minutes for 30 minutes
- 4 readings every 15 minutes for 60 minutes
- 2 readings every 30 minutes for 60 minutes
- 1 reading every 60 minutes for remaining test time

Area of influence of the well shall be determined by at least one observation well. Observation well requirements may be waived for wells over 2,000 feet in depth. Also, observation shall be made at all existing wells within a 1,000 foot radius regardless of well depth.

Wells shall be at an elevation higher than the maximum flood level and high enough to permit drainage away from the facilities. All wells, treatment plants, and above ground appurtenances shall be located at least 500 feet from any possible source of contamination and shall be enclosed with a 6-foot high chain link fence with 3 strands of barbed wire above the fence. They shall be provided with a double gate entrance for pedestrian and truck use.

The maximum pumping permitted from each well field shall be taken at 50% of the normal capacity of the well as determined from the aforementioned 48-hour test. Emergency electrical power must be provided.

D. Construction of Treatment Plants

No general rules can be formulated for the design of treatment plants and each case will be considered individually based upon the raw water quality. The type and method of treatment must be approved by the New Jersey State Department of Environmental Protection. Treatment Plant plans and specifications must include provisions for lawns, shrubbery, paved roads and sidewalks. Plants shall be architecturally compatible with the environment.

The entire property must be surrounded by a 6-foot high chain link fence with 3 strands of barbed wire angled out above the fence.

Separate gates must be provided for pedestrian and truck use.

Detailed estimates of operating and maintenance cost of the proposed treatment plant must be submitted with the engineer's estimate.

Emergency electrical power must be provided.

All standards of U.S. Public Health Service applicable to protection of the water sources, wells, water mains, equipment, and treatment works shall be met in the design of treatment plants.

The finished water shall meet, in addition to the standards set forth in Paragraph A.5. above, all other potable water standards adopted by the appropriate state and federal regulatory agencies.

E. Construction of Booster Pumping Stations and Storage Tanks

In general, the requirements of Construction of Wells and Treatment Plants are applicable.

Suitable controls and remote telemetering must be provided from the pumping station or storage tank to the Authority's center of operations.

Storage tanks may be either steel or reinforced concrete, and shall be constructed by firms competent in the field of tank erection.

F. As-Built Plans

After construction and before final acceptance by the Authority, the Applicant shall furnish to the Authority, one linen tracing or mylar, in ink, approved by the Engineer, and one set of prints black on white, of each drawing showing the overall plan of the distribution system, plans and details of the distribution system and all facilities as constructed.

2.10 Approval of Plans by State Agencies and Others

Approval of plans by the State of New Jersey Department of Environmental Protection, Division of Water Resources, must be obtained and will be a condition of the Authority's final approval. The Applicant shall obtain permits for all stream crossings or encroachments from the State of New Jersey Department of Environmental Protection, Division of Water Resources, and Corps of Engineers where required. Permits to construct water main and/or other structures within the right-of-way limits of State, County, and Municipal roads and all Railroads must be secured and paid for by the Applicant.

Water diversion rights will be secured by the Applicant in the name of the Authority, from the State of New Jersey Department of Environmental Protection, Division of Water Resources. Well drilling permits shall be obtained by the Applicant.

No work shall be closed or covered up until it has been duly inspected and approved for proper and satisfactory construction and installation. Should uncompleted or unapproved work be covered, the developer shall uncover all work so that it can be properly inspected and approved; and after such inspection and approval he will properly repair and replace all work found defective, unsatisfactory, and not in accord with the Plans and Specifications, and after such repair and replacement, he will bring all work to the completeness and status as it was before it was closed and covered.

Prior to making pressure tests, all air shall be vented from the line and the pipe then filled and remain filled with water for a period of at least 12 hours. After absorption is complete, the pipe(s) and appurtenances shall be pressure-tested for a period of one hour under a pressure equal to twice the maximum possible pressure in each pressure zone but in any case not less than 150 psi.

A leakage test shall be conducted after the satisfactory completion of the pressure test.

The duration of each leakage test shall be 2 hours; and during this period, the main shall be subjected to a pressure equal to twice the maximum possible pressure in the pressure zone, but in any case not less than 150 psi, and shall not be permitted to fall more than 10 psi below that amount.

Leakage is defined as that quantity of water to be supplied into the newly laid pipe, or any valved section thereof, necessary to maintain the specified leakage pressure after the pipe has been filled with water and the air expelled.

No pipe installation will be approved until the leakage is less than the number of gallons per hour as determined by the following formula:

$$L = \frac{ND}{3,700} P$$

where:

- L = Allowable leakage in gallons per hour
- N = Number of joints in the length of pipe line tested
- P = Average test pressure during the test
- D = Nominal diameter of pipe

If leakage occurs greater than the allowable quantity specified, the defective joints or pipes shall be located and repaired until the leakage is within the acceptable allowance.

C. Disinfection

Before being placed in service, all water mains, appurtenances, pipe, treatment units and storage tanks shall be disinfected. The mains and tanks shall first be thoroughly flushed to remove all dirt and foreign matter and then filled with water containing a dosage of 50 ppm of chlorine. The chlorinated water shall be retained in the mains and tanks for at least 12 hours after which the mains and tanks shall be flushed. The Applicant may, at his option, chlorinate storage tanks by spraying all interior surfaces with a solution containing 500 ppm concentration of chlorine.

A solution of not less than one percent of the tank capacity shall be prepared at this concentration and sprayed on all surfaces. The tank shall then stand with drain closed for at least 12 hours. When the required time has elapsed, the tank shall be drained and flushed with water.

After flushing, the system shall be filled with water and a bacterial analysis, by a licensed laboratory, shall be made. The results shall meet the standards as set forth by the State of New Jersey Department of Environmental Protection.

2.12 Use of the Water System

A. Use of Water System by the Authority

During construction and before final acceptance, the Authority shall have the right to use any portion completed without waiving their right to order correction of any defects.

B. Illegal Use of System

Use of the active portion of the water system for construction, flushing of sewers, and the like is strictly prohibited without the expressed permission of the Authority. Any other use not specified herein which the Authority determines "Illegal Use of System", is strictly prohibited, and is subject to penalty and/or fine as may be prescribed by law.

2.13 Acceptance of Improvements by the Authority

After construction of all proposed improvements has been completed, the applicant will:

- A. Certify that the construction has been completed in accordance with the approved plans and specifications.
- B. Convey title by metes and bounds description to all lands, easements, and improvements not previously transferred.
- C. Affidavits of title for land, easements, and equipment, and a recitation thereon that everything conveyed to the Authority has been paid for in full. Corporate resolution authorizing said transfers if applicable.
- D. Copy of filed subdivision map showing all easements.
- E. Surveys for plant or pump station sites and easements.
- F. Bill of Sale for all equipment and lines, including warranties from manufacturers of equipment.
- G. Releases from the following: Materialmen, Suppliers, Contractors, Subcontractors, Laborers, Lending Institutions.
- H. As-built plans
- I. Post Surety Maintenance Bond in a form approved by the Authority's Attorney equal to 10% of the Performance Bond, guaranteeing the satisfactory performance and functioning of the improvements for a minimum one year.

2.14 Application for Connection to Existing Water System

This application shall be accompanied by fees as set forth therein, on a form provided by the Authority.

Water connection shall be made to a street main only under the review and inspection of the Authority's authorized representative. Connection to the water main shall be made in accordance with methods set forth within these Rules and Regulations.

A water service connection shall be defined as the pipe and appurtenances as set forth below, between the Authority's street main and the individual property line.

Water pipe from the property line to a building is under the jurisdiction of the Board of Health through its plumbing inspector and his approval will be required before the Authority will permit usage of the facility.

The water pipe and its maintenance and/or repair, is solely the responsibility of the landowner from the Authority's shut off to the building.

2.15 Compliance with Rules and Regulations

The applicant shall comply with all the Rules and Regulations as set forth herein. Failure to do so will result in "stop work order" by the Authority. These Rules and Regulations are minimum requirements, and are not intended to replace detail specifications which are the responsibility of the applicant. They are intended to apply to usual and not the exceptional conditions. These Rules and Regulations are subject to amendments by the Weymouth Township MUA. The Authority reserves the right to specify additional requirements.

SECTION 3.0

RULES AND REGULATIONS FOR THE CONSTRUCTION OF SANITARY SEWER EXTENSIONS, PUMPING STATIONS AND TREATMENT PLANTS

3.0 GENERAL PROVISIONS

The policy of the Authority shall be to make no further extensions to the existing sanitary sewerage collection and treatment system unless paid for by those requesting the same. No facilities for the collection and treatment or disposal of sewerage within the Township shall be constructed unless the Authority shall give its consent to the Authority Engineer who shall approve plans and specifications. Accordingly, as subsequent construction of sewerage facilities are to be consented to and approved by the Authority, the Authority plans to encourage connections to its system whenever possible and practicable so as to secure the proper treatment and disposal of sewerage in the Township. Sewer lines needed for any future connections, together with related appurtenances shall be installed by those requesting the service.

All sewer mains and appurtenances including manholes, and force mains, whether installed by the Weymouth Township Municipal Utilities Authority or not, shall be owned and maintained by the Authority when located in dedicated municipal streets, or rights-of-way. Ownership and maintenance of facilities installed in other than dedicated municipal streets or rights-of-way may be assumed by the Authority at its discretion. If the Authority does not assume ownership and maintenance of said facilities, then a private organization shall be established (i.e. homeowners association, condominium association, etc.) to assume ownership and maintenance of the facilities. The document creating this organization and defining its responsibilities shall be subject to review by this Authority.

It shall be the policy of the Authority further, to charge connection fees for the privilege of connection to its sewer system in accordance with Schedule of Rates. Any common facilities installed under the provisions of this section shall be transferred to the Authority as hereinafter described.

3.1 Conditions Requiring the Installation of Sewerage System

Any major subdivision or any multi-family structure regardless of volume of flow, and all non-residential development such as schools, commercial buildings, industrial buildings and all other structures shall be required to connect with the nearest existing sanitary sewer in the Township, and shall furnish and install a sewerage collection system in accordance with the provisions of these rules and regulations, except as herein provided.

In the event that the applicant's lands are deemed by the Authority to be too remote from the Authority's sewerage collection system; then a treatment plant for the treatment of sewage may be required. Said treatment plant and the location thereof shall be subject to approval by the Authority in accordance with the standards and requirements as hereinafter set forth, and as may be required by any governmental regulatory agencies having jurisdiction thereof.

3.2 Applications to the Authority

Prior to consideration, applications shall be filed with the Authority together with the required fees.

All tentative and final applications must be submitted at least 15 days before a regular scheduled meeting of the Authority. All applications are to be signed by the Owner or by a duly authorized agent or representative and if signed by an authorized agent, shall be accompanied by proof of authorization by affidavit of the owner.

3.3 Application for Tentative Approval

The applicant shall submit a tentative application in duplicate, on a form provided by the Authority.

3.4 Instructions for Application for Tentative Approval

- A. A non-refundable application fee of \$20/unit, minimum of \$50.00 shall be submitted with the application.
- B. A fee of 2% of the estimated cost of construction (minimum \$1,000.00) as determined by the Applicant's Engineer, subject to the review and approval of the Authority's Engineer, shall be submitted with the application. Said fee shall be deposited in an escrow account to cover the cost of review of the project. The escrow account shall be replenished from time to time as deemed necessary by the Authority.

The application shall be accompanied by the following supporting data:

1. Engineer's Report
2. General Map of the entire project, 7 copies.
3. Plans of all proposed sewers, including lateral connections to all property lines, 7 copies.
4. General plan for sewage pumping stations and treatment plants.

D. Data shall contain information described below:

1. Engineer's Report

A complete engineer's report setting forth the basis of design shall be submitted to the Authority for each project.

All sanitary sewers shall be designed to carry four times the average flow, estimated 25 years in advance for the contributory area. Average flow shall be assumed to be 100 gallons per person, per day, three persons per unit.

Sewers shall be designed to flow with a minimum velocity of 2 feet per second and a maximum velocity of 10 feet per second at full flow based on Manning's Equation with $n = 0.013$. Inverted siphons shall be designed for minimum velocity of 3 feet per second (3 fps) and a maximum velocity of 6 feet per second (6 fps).

Material specifications and construction details shall be set forth and comply with those specified under "Detailed Information on Design and Construction of Sewerage Systems".

2. General Map of the Entire Project

A general map of the entire project shall be furnished to show sewers and pumping stations for the whole area at a scale of 1" = 200' and a key map at a scale of 1" = 2000'.

3. Plans of all Proposed Sewers

Properly entitled plans shall be of uniform size, 24 x 36 inches or 30 x 42 inches, with a 1/2 inch border on top, bottom, and right side and a 2 inch border on the left side. Seven sets of plans shall be submitted and show the following:

- a. Details - Plans shall show all existing and proposed improvements including underground utilities, water mains, sewer mains, storm drains, etc. Contours will be shown at 2 foot intervals with proposed streets and surface elevations at all breaks in grade and street intersections,

tributary areas with population per acre, the true or magnetic meridian, boundary line, title, data and scale. Any area from which sewage is to be pumped shall be indicated clearly. All sheets shall be numbered. Drawings not meeting reasonable engineering standards as to accuracy and neatness will not be accepted.

- b. Symbols - Sewers proposed under the application shall be shown by a solid line (—^{ss}—); existing sewers shall be shown by a dashed line (--ss--). All topographical symbols and conventions shall be the same as those of the U.S. Geological Survey. A legend shall be provided on all plans defining the symbols as shown on the plan.
- c. Elevations - All permanent bench marks of U.S. Coast and Geodetic Survey shall be shown. Elevations of street surfaces shall be placed outside the street intersections, ends of lines, and at changes of grades shall be written parallel with the sewer lines and between the street lines. The elevations of street surfaces shall be shown to the nearest 0.1 foot; the sewer inverts to the nearest 0.1 foot. Sufficient bench marks shall be permanently established for the area.
- d. Distances, Grades and Sizes - The distances and stationing between manholes, grades in decimal, sewer sizes, strength class, and material shall be shown on the plans. Arrows shall show the direction of the flow. Plans, profiles and hydraulic analyses of the existing sanitary sewer from the applicant's point of connection to the point of ultimate disposal by the Weymouth Township Municipal Utilities Authority shall be included.

4. General Plans for Sewage Pumping Stations and Treatment Plants

The plans for the pumping stations and treatment plants shall include a general site plan showing boundaries, contours, proposed pumping stations or treatment plants, with capacities, underground piping, underground or overhead wires.

- D. The following will govern the approximate sizes and locations of sewers and places of discharge:

Sewage received into the facilities of the Authority shall not impair or exceed the hydraulic capacity of existing facilities as determined by the Authority or the Authority's Engineer.

If the size of any sewer main, as shown by the application to be installed by the applicant is inconsistent with the requirements of the area, the applicant shall install mains, as required by the Authority. The Authority agrees to pay the applicant the difference in the material cost plus the cost of the additional excavation and additional cost of labor as determined by the Authority or its Engineer.

If the Authority requires the installation of a pumping station of greater capacity and/or depth than that capacity determined by the Authority as necessary to serve the Applicant, the Authority shall pay said applicant the difference between the cost of the facilities necessary to serve the applicant and the facilities required by the Authority.

In the event the applicant requests the substitution of a pumping station and a force main in place of a gravity sewer from the applicant's land to any existing sewer, and the Authority agrees to the substitution, the applicant will pay to the Authority in addition to all other fees, the cost of power, labor, and maintenance of the pumping station capitalized at 5% for 40 years. Power costs shall be calculated by using the flow, lift, and power unit costs. Labor and maintenance will be set at \$2,500.00 per year for each 100 gallons of sewage per minute pumped by the largest pump.

If the Authority requires a treatment plant of greater capacity than that capacity determined by the Authority as necessary to serve the applicant, the Authority shall pay said applicant the difference between the cost of the treatment plant necessary to serve the applicant and the cost of the treatment plant required by the Authority.

The Authority will not assess the increased cost, if any, of the Engineer's review and inspection fee when the increased cost of construction results from an order by the Authority.

All sewers must be designed on a separate system plan, in which all water from roofs, cellars, streets, and any other areas must be excluded.

Tentative approval shall expire 2 years from the date thereof.

3.5 Application for Final Approval

Upon notification by the Authority that tentative approval has been granted, an application for final approval may be filed in duplicate on a form provided by the Authority.

3.6 Instructions for Application for Final Approval

- A. A fee of 2% of the estimated costs of construction (minimum \$1,000.00) as determined by the Applicant's Engineer subject to the review and approval of the Authority's Engineer, shall be submitted with the application. Said fee shall be deposited in an escrow account to cover the cost of review of the project. The escrow account shall be replenished from time to time as deemed necessary by the Authority.

The application shall be accompanied by the following supporting data:

1. Profiles of all proposed sewers, 7 copies.
2. Details of construction of manholes, siphons, connections, and other sewer appurtenances, 7 copies.
3. Detailed plans for sewage pumping stations and treatment plant, 7 copies (if applicable).
4. Specifications for the construction of proposed sewerage system and appurtenances including sewage pumping stations and treatment plants, 7 copies.
5. Detailed estimate of entire construction cost, 7 copies.
6. Performance Bond.

7. Three copies of the Engineer's report, together with other data furnished with the application for tentative approval, such as hydraulic analyses of existing down stream sewerage facilities, if requested by the Authority.
8. Proof of title to all lands and copy of proposed conveyances and easements.
9. An application form, filled out in the name of the Authority, to the New Jersey State Department of Environmental Protection when the Authority agrees to accept ownership and maintenance of the proposed facilities.

Should the Authority decide not to accept ownership and maintenance of the proposed facilities, applicant shall process an application in his name, said application package subject to review and approval by the Authority.

Prior to endorsement of the application package by the Authority, the applicant shall post the Performance Guarantee with the Authority.

10. An application form, to the Atlantic County Utilities Authority, filled out in the name of the Authority, when the Authority agrees to accept ownership and maintenance of the proposed facilities.

Should the Authority decide not to accept ownership and maintenance of the proposed facilities, applicant shall process an application in his name, said application package subject to review and approval by the Authority.

B. Data shall contain information described below:

1. Profiles - Profiles shall show all manholes, siphons, pumping stations and elevations of stream crossings. Gradients and sizes of sewers, surface elevations, and sewer inverts shall be shown at each manhole. They shall be drawn to standard scales and the scales shall be shown on each sheet. An index of streets shall also be shown on each. Profile sheets should be numbered consecutively. Drawings shall conform to the size specified under "Tentative Approval".

2. Details of Construction of Manholes, etc. - Details of manholes, siphons, etc. shall accompany the plans. Details shall be drawn to standard scales to show clearly the nature of design.
3. Detailed Plans for Sewage Pumping Stations and Treatment Plants - The plans for the pumping stations and treatment plants shall include a general site plan showing boundaries, streams, contours, proposed pumping stations, underground piping, underground or overhead wires. The plans shall show the general arrangement of mechanical and electrical equipment, piping, valves, fittings, etc., within the various structures. A flow diagram shall be included for treatment plants. The plans shall conform to the size specified under "Tentative Approval".
4. Specifications - Complete specifications for the construction of the proposed sewerage system and appurtenances, including sewage pumping stations and treatment plants, shall accompany the plans. They may be omitted for sewer extensions, provided specifications for the sewer system are already filed and reference is made to them in the application. The requirements of all other governmental regulatory agencies, must be satisfied by the submitted specification.
5. Estimate of Costs - An itemized list of improvements to be constructed shall be furnished and shall include cost of rights-of-way and easements as may be required. The estimate of costs will be subject to review and approval of the Authority's Engineer.
6. Performance Bond - A Performance Bond in a form approved by the Authority and Authority's Attorney in an amount of 100% of the total construction cost as defined in "Estimate of Costs," guaranteeing complete construction within the time period to be specified by the Authority, and further guaranteeing that said construction will be in accordance with the Rules and Regulations of the Authority, the plans and specifications, engineer's report, and the cost estimates as approved by the Authority and to the satisfaction of the Authority's Engineer.

7. Engineer's Report - The engineer's report shall include but not be limited to, all information required by the New Jersey Department of Environmental Protection and the Atlantic County Utilities Authority.
8. Proof of Title - A copy of a title report, title policy or attorney certificate, establishing that no part of the system is encumbered so as to prevent, unduly restrict, or circumscribe the ability of the applicant to make all conveyances, transfers, and dedications incidental to vesting in the Authority, title to the entire system and its appurtenances together with copies of all proposed documents to effect such conveyances, transfers, and dedications.
9. Application to the New Jersey Department of Environmental Protection - The applicant shall as a condition to receipt of final approval by the Authority, prepare and submit to the New Jersey Department of Environmental Protection, all required plans and specifications, Engineer's Report and the New Jersey DEP form in duplicate. The applicant shall prepare and submit the entire exhibit to the NJDEP in the name of the Authority, when the Authority agrees to accept ownership and maintenance of the proposed facilities.

Should the Authority decide not to accept ownership and maintenance of the proposed facilities, applicant shall process an application in its name, said application package subject to review and approval by the Authority.

Prior to endorsement of the application package by the Authority, the applicant shall post the Performance Guarantee with the Authority.

10. Application to the Atlantic County Utilities Authority - The applicant shall as a condition to receipt of final approval by the Authority, prepare and submit to the Atlantic County Utilities Authority form in duplicate. The applicant shall prepare and submit the entire exhibit to the Atlantic County Utilities Authority in the name of the Authority, when the Authority agrees to accept ownership and maintenance of the proposed facilities.

Should the Authority decide not to accept ownership and maintenance of the proposed facilities, applicant shall process an application in its name, said application package subject to review and approval by the Authority.

Final approval shall expire 2 years from the date thereof.

3.7 Inspection Fees

The applicant shall pay an inspection fee to the Authority in addition to the application fee based on the said estimate of costs. Payment of the inspection fees shall be made in the following manner. As a condition of final approval and prior to commencing actual construction, the applicant shall deposit with the Authority 6 1/2% of the said estimate of costs.

3.8 Application for a Sewer Connection in Conjunction with Final Approval of Newly Constructed Sewerage Facilities

This application shall be filed in duplicate on a form provided by the Authority. The applicant shall pay a connection fee, as provided in the current schedule of rates and charges adopted by the Authority which shall be paid to the Authority upon submission of an application for connection.

Sewer connections are applicable only for the Block and Lot numbers of the proposed project. Connections are not transferable to other lots.

Sewer connections will be awarded after final approval has been granted. The applicant shall pay the connection fees within 30 days from the date of the award of the connections, but in no case shall the Authority provide the necessary state endorsements prior to the payment of the connection fees.

If construction of the project is not started within two years from the date of the award of the connections to the applicant, all sewer connections and all applicable connection fees paid shall revert to the WTMUA.

In the event that construction is commenced, but within two years of the date of the award the applicant has not used all connections, any unused connections shall revert to the WTMUA and the applicant shall receive a refund of the connection fees for the unused and rescinded connections.

Should a portion of the applicant's property front on a previously existing sewer, an application for sewer connection shall be filed with the Authority. This application shall be a form provided by the Authority accompanied by all fees set forth therein on.

Sewer connections shall be made to a sewer main only under the review and inspection of the Authority's authorized representative. Connection of the lateral shall be made through an approved wye.

A sewer service connection shall be defined as the pipe and appurtenances, as set forth below, between the Authority's sewer main and the individual property line.

Sewer pipe from the property line to a building is under the jurisdiction of the Board of Health through its plumbing inspector and his approval will be required before the Authority will permit usage of the facility.

The above shall also apply where a landowner is required by the Authority to connect to an existing sewer main.

The landowner is solely responsible for the maintenance and/or repair of the sewer pipe between the building and the Authority's clean out.

3.9 Detailed Information on Design and Construction of Sewage Systems

A. Sewer Pipe

1. General - Materials used in the construction of sewers, force mains, and outfalls shall be as follows: Gravity sewers shall be constructed of reinforced concrete, PVC, or as may be otherwise determined necessary by the Authority or the Authority's Engineer.

Inverted siphons, force mains and outfalls shall be constructed of cast iron or ductile iron pipe unless otherwise permitted by the Authority. Inverted siphons shall consist of 2 pipes with provision for flushing. Flow control gates shall be provided within the chambers.

2. Reinforced Concrete Pipe - Concrete pipe shall meet all the requirements of ASTM specifications C76. All pipe shall be Class IV strength except where stronger pipe is required.
 - a. For depths less than 3 feet, measured from the top of the pipe, installed under traffic areas, Class IV pipe shall be required.
 - b. The following trench depths are maximum for the pipe classes noted, installed with Class C, ordinary bedding.

<u>Pipe Diameter (Inches)</u>	<u>Maximum Width of Trench at Top of Pipe</u>	<u>Depth-Feet Pipe Class</u>	
		<u>IV</u>	<u>V</u>
12"	3' - 0"	6.5	18.0
15"	3' - 8"	6.0	14.0
18"	4' - 0"	7.0	16.0
21"	4' - 3"	8.5	17.5
24"	4' - 6"	9.0	20.0
30"	5' - 0"	10.5	22.5
36"	5' - 8"	11.0	22.0

c. The existence of clayey soils and other unusual loading conditions not covered by paragraphs a or b above shall be given special consideration.

3. Cast Iron Pipe - Cast iron pipe shall be cast centrifugally in metal or sand molds in accordance with ANSI specification A21.6 or A21.8. Wall thickness of pipe shall be determined in accordance with ANSI specifications A21-1; but in no case shall the wall thickness be less than specified for Class 150 pipe.
4. Ductile Iron Pipe - Ductile iron pipe shall be cast centrifugally in metal or sand molds in accordance with ANSI Specification A-21.51 (latest edition); wall thickness of pipe shall be determined in accordance with ANSI Specification A21.50, but in no case shall the wall thickness be less than that specified for Class 50 pipe, and the pipe shall have a mortar lining as designated by ANSI A-21.4 (latest edition).
5. PVC Pipe - Polyvinylchloride sewer pipe shall conform to all requirements of ASTM D-3033 (latest edition) or ASTM D-3034 (latest edition) except that solvent weld joints will not be allowed. Internal surfaces shall be smooth and free of undulations. Maximum allowable length shall be 20 feet. PVC sewer pipes shall be SDR 35.
 - a. No pipe shall be installed with less than four (4) feet of cover without special bedding.

b. Maximum trench width at the top of the pipe shall be three (3) times the pipe diameter in well compacted granular material. In unconsolidated material the trench shall be opened to five (5) times the pipe diameter and a minimum (4) inch layer of an approved compacted granular material placed below the pipe for the full width of the trench. Granular backfill shall then be placed and mechanically compacted in layers of six (6) inches or less to one (1) foot above the top of the pipe for the full width of the trench. All the above material shall be compacted to 85 percent of its maximum density by an approved method and shall be subject to testing as required by the engineer for the Authority.

6. Joints - Joints for sewer pipes shall be specified below:

- a. Reinforced Concrete - Rubber gasket equal to Lock-Joint for non-pressure type.
- b. Cast Iron - Rubber gasket equal to Tyton.
- c. Ductile Iron - Rubber gasket equal to Tyton.
- d. PVC Pipe - Elastomeric gasket joint equivalent to Certain-Teed Fluid-Tite, Johns-Manville Ring-Tite, or Precision Elastic Pipe's E-Z seal.

7. Cushions

- a. Class C Ordinary Bedding - shall be defined as that method of bedding sewers in which the sewer is bedded on approved granular material with ordinary care in an earth foundation shaped in undisturbed earth so as to fit the lower part of the sewer exterior with reasonable closeness for a width of at least 50% of the sewer diameter, and in which the remainder of

the sewer is surrounded to a height of at least 0.5 feet above its top with approved granular materials shovel placed and shovel tamped to completely fill all spaces under and adjacent to the sewer, all under the general direction of a competent engineer and with frequent inspection by a competent inspector during the course of construction.

- b. Concrete Cradle Bedding - is that method of bedding sewers in which the lower part of the sewer exterior is bedded in 3,000 psi concrete or better, without reinforcement, having a minimum thickness under the pipe of one-fourth its nominal inside diameter and extending upward to a height equal to one-half of the nominal inside diameter.
- c. Concrete Encased Pipe Bedding - is that method of bedding sewer in which the entire sewer exterior is encased in 3,000 psi concrete or better, minimum 6 inches of concrete all around.

8. Manholes - Manholes shall be provided at ends of sewer lines, at intersections and at changes of grade or alignment. Distances shall not exceed 400 feet. Where sewers enter manholes, and the difference in crown elevation between the incoming and outgoing pipes is equal to or greater than 2 feet, drop pipes shall be provided and drop manholes shall be built. Manholes shall be precast concrete.

Precast manhole barrels and cones shall be reinforced concrete pipe and fittings formed to ASTM Specification C-478, with round rubber gasketed joints, conforming to ASTM Specification C-361. Maximum absorption shall be in accordance with Specification C-76.

Manhole frames and covers shall be of cast iron conforming to Specification ASTM 48-83. All manhole covers in remote areas shall be provided with a locking device. The letters "WTMUA" and "SEWER" shall be cast integrally in the cover. Typical manhole frame and cover desired is a Campbell Foundry 1541 or approved equal.

As differential settling may occur at the connection between sewer pipes and manholes, the following precautions shall be taken to prevent pipe failure near the joint:

When a rigid connection is made at the manhole, a short section of pipe shall be used to provide a pipe joint just outside the manhole. This shall be followed by a three (3) to six (6) foot pipe section.

When a flexible type connection is used at the manhole, the first pipe section shall be three (3) to six (6) feet long.

In either case, proper bedding of the pipe and the manhole is to be maintained.

B. Pumping Station

All raw sewage shall be screened before pumping. At the option of the Authority, comminutors may be required in lieu of screens. At least two (2) pumps or ejectors shall be provided, each capable of handling the total peak flow. Ejectors will not be permitted for flows exceeding 100 gallons per minute.

Force main velocities shall be not less than 2 feet per second at normal pumping rate.

Pumps shall be installed in dry wells deep enough to maintain a suction head at starting. The dimensions of dry wells shall be determined by the Authority Engineer upon review of plans. Wet and dry wells should be provided with adequate entrances, ventilation and drainage.

Wet wells shall slope toward the pump suction. Pump suction shall terminate 90° flared elbows. Normally, the capacity of the wet well shall be 10 minutes flow at the average dry weather rate. An auxiliary source of power housed in a superstructure to conform to the neighborhood architecture shall be provided for all electrically driven pumps, unless waived by the Authority.

Each pumping station must be on a full size lot based on the existing zoning ordinance. The Authority reserves the right to increase or decrease said lot size requirements. The plans and specifications must include provision for lawns, shrubbery, paved drive and concrete walk. The

entire property must be surrounded by a 6-foot chain link fence with three strands of barbed wire above the fence. Truck and pedestrian gates shall be provided. The paved drive shall have a total thickness of 8 inches, being 6 inches of compacted road gravel and a 2 inch FABC finished surface. The concrete walk shall be 4 inch minimum thickness 3000 psi.

In pumping stations exceeding 1000 gallons per minute, electrical motors and power equipment shall not be installed in subsurface chambers. A solid wall shall be constructed between the wet and dry wells extending to the floor of the superstructure. Superstructure, if required, shall conform to the neighborhood architecture, unless waived by the Authority.

Automatic sound alarms shall be installed independently of station power and they shall give warning of high and low water and power failure. These alarms shall be connected to the Authority's master alarm panel.

Adequate light, ventilation, heat and fresh water supply with hose outlet shall be provided for all stations.

Complete repair tools and accessories shall be provided with the pumps. Space must be provided in the superstructure for housing generator and/or motors and electrical equipment, for gas chlorination equipment and cylinders. All piping must be provided. If the time of travel at the rate of 2 feet per second of the sewage from the most remote point to the Hamilton Township Municipal Utilities Authority treatment plant is equal to or greater than 2 hours, gas chlorinator, scale, and equipment must be furnished.

Detailed operational costs of the pumping station must be submitted with the engineer's estimate.

Submersible pump stations will be considered upon submission of written application.

C. Treatment Plant

No general rules can be formulated for the design of treatment plants and each case shall be considered individually, based upon the discharge of effluent. The type and method of treatment must effect at all times a minimum reduction of 95% in biochemical oxygen demand (BOD) of the received sewage at the plant, the BOD of the effluent not to exceed 15 parts per million (15 ppm), unless stricter requirements are imposed by the New Jersey Department of Environmental Protection.

Treatment Plants should be located a minimum of 1000 feet from the nearest dwelling or other building. Exceptions to this rule may be made depending on the type of treatment to be used, but in no case will a treatment plant structure be permitted less than 250 feet from the boundary line of the treatment plant property.

Treatment Plant plans and specifications must include provisions for lawns, shrubbery, paved roads, and sidewalks and the entire property must be surrounded by 6 foot high chain link fence with 3 strands of barbed wire above the fence.

Separate gates must be provided for pedestrian and truck use. Detailed estimates of operating and maintenance costs of the proposed treatment plant must conform to all applicable, County, State, and Federal Regulatory Agency requirements.

D. As-Built Plans

After construction and before final acceptance by the Authority, the applicant is to furnish the Authority one linen tracing or mylar in ink approved by the Engineer, and one set of black on white prints of each drawing showing the sewers, lateral connections, etc., as constructed.

3.10 Approval of Plans by State Agencies, Atlantic County Utilities Authority and Others

Final approval by the Authority shall be subject to approval of plans by the New Jersey State Department of Environmental Protection. The applicant shall obtain all permits required by the NJDEP and Atlantic County Utilities Authority. Permits to construct sewers and/or other structures within the rights-of-way limits of State, County and Municipal roads and all Railroads must be secured and paid for by the applicant. The applicant must secure any necessary clearance from any public utility involved.

3.11 Inspection of Sewerage Systems during the Course of Construction

A. General

The applicant shall give 72 hours notice to the Authority or its authorized representative prior to construction. All construction of sewerage systems shall comply with the approved plans and specifications and shall be subject to construction review or inspection by the Authority or its authorized representative who may direct or order discontinuance of construction.

The applicant shall submit a progress report together with the cost of construction at the end of each month to the Authority.

No sewer lateral connections shall be made to a street main whether pressure tested or not, unless said connection is made under the review and inspection of the Authority's representative.

A temporary leak-proof bulkhead type plug shall be installed in the upstream (inlet) side of the manhole furthest downstream in any sewer main or branch under construction and shall remain intact and unloosened until written permission is received from the Authority or its authorized representative, to remove same.

This permission will not be granted until each section of the sewer has been cleaned and flushed in a manner acceptable to the Authority or its authorized representative.

B. Testing

All sewers shall be subjected to either an infiltration or exfiltration test. Exfiltration tests shall be conducted in lieu of infiltration test when the pipe has been laid above the ground water level. The tests shall be performed between two manholes or as otherwise directed by the Authority or its authorized representative and shall include all related sewerage facilities including the lateral connections. At the discretion of the Authority, leakage detection by an air test method may be specified. The contractor shall furnish all labor, material and equipment necessary for the testing.

Exfiltration tests shall be under at least five-foot head or a pressure corresponding to a head equal to the depth of the lower manhole of the section under test.

Allowable infiltration or exfiltration shall not exceed a rate of 50 gallons per mile, per inch of diameter of sewer per 24 hours. Any pipe, joint or other part of the sewer constructed found to show either infiltration or exfiltration in excess of the permissible limit shall be repaired, or removed and replaced, before proceeding with construction.

Upon written request by the applicant, the Authority will supply a detailed method and procedure for testing.

3.12 Use of the Sewer System

A. Use of Sewer by Authority

During construction and before final acceptance, the Authority shall have the right to use any portion completed without waiving its right to order correction of any defects.

B. Illegal Use of System

Use of the system for the discharge of sump pumps, or drainage from cellar drains, leaders, downspouts, drainage tile, cellar pits or pumping out septic tanks or septic tank trucks and any other use not included herein which the Authority determines "Illegal Use of System," is strictly prohibited, and is subject to penalty and/or fines as may be prescribed by law.

3.13 Acceptance of Improvements by the Authority

After construction of all proposed improvements has been completed the applicant will:

- A. Certify that the construction has been completed in accordance with the approved plans and specifications.
- B. Convey title by metes and bounds description to all lands, easements, and improvements not previously transferred, together with title policies therefor.
- C. Affidavits of Title for land, easements, and equipment, and a recitation thereon that everything conveyed to the Authority has been paid for in full. Corporate resolution authorizing said transfers if applicable.
- D. Copy of filed subdivision map showing all easements.
- E. Surveys for plant or pump station sites and easements.
- F. Bill of Sale for all equipment and lines, including warranties from manufacturers of equipment.
- G. Releases from the following: Materialmen; Suppliers; Contractors; Sub-contractors; Laborers; Lending Institutions.
- H. As-built plans.

- I. Post Surety Maintenance Bond in a form approved by the Authority's Attorney equal to 10% of the Performance Bond, guaranteeing the satisfactory performance and functioning of the improvements for a minimum one year.

3.14 Application for Connection to Existing Sewerage System

This application shall be accompanied by fees as set forth therein on a form provided by the Authority.

Sewer connection shall be made to a street main only under the review and inspection of the Authority's authorized representative. Connection of the lateral shall be made through an approved wye or saddle.

A sewer service connection shall be defined as the pipe and appurtenances, as set forth below, between the Authority's street main and the individual property line.

Sewer pipe from the property line to a building is under a jurisdiction of the Board of Health through its plumbing inspector and his approval will be required before the Authority will permit usage of the facility.

The sewer lateral and its maintenance and/or repair, is solely the responsibility of the landowner from the Authority's clean out to the building.

3.15 Regulations Governing Wastes Discharged or to be Discharged into Sanitary Sewers

Sewage received into the facilities of the Authority shall not;

- A. Be in such quantity as to impair or exceed the hydraulic capacity of such facilities as determined by the Authority's Engineer.
- B. Contain any amount of solid matter that will prevent self-scouring flow when carried in sewers installed at the minimum design values. Any property owner determined responsible by the Authority for causing such solids loadings shall cause said solids to be removed by an Authority, or other regulatory agency, approved pre-treatment system. Said system shall be furnished and installed by the property owner at his entrance to the system.

- C. Be of such a nature as to, by either chemical or mechanical action: impair the strength or the durability of the sewer facilities; create explosive conditions; contain any matter, material or substance, which after undergoing normal treatment in the respective sewage treatment plant of the Authority, would not be removed from the effluent from such plant and would thereby be the cause of polluting any stream or body of water into which such effluent is discharged.
- D. Have a flash point lower than 235°F., as determined by Tagliabus (Tag.) closed cup method;
- E. Have a pH index value lower than 5.5 or higher than 9.0;
- F. Include any radioactive substance, unless written consent has been obtained for its inclusion;
- G. Include any garbage other than that received directly in public sewers from residences;
- H. Be discharged from tank trucks into manholes of the sewerage system.

For industries discharging industrial waste, a written contract with the industry will be required.

Requirements established by the Atlantic County Utilities Authority are incorporated herein by reference and made part hereof.

3.16 Compliance with Rules and Regulations

The applicant shall comply with all of the Rules and Regulations as set forth herein. Failure to do so will result in "stop work order" by the Authority. These rules and regulations are minimum requirements, and are not intended to replace detail specifications which are the responsibility of the applicant. They are intended to apply to usual and not the exceptional conditions. These rules and regulations are subject to amendments by the Weymouth Township Municipal Utilities Authority. The Authority reserves the right to specify additional requirements.

SECTION 4

RULES AND REGULATIONS FOR WATER SERVICE

4.0 WATER SERVICE CONNECTION

A. New Connections:

The Authority will maintain all service lines from the main up to and including the curb stop and box, which shall be placed inside the curb line. Meter pits shall not be permitted on individual homes. The excavation and materials for a service tap will be provided for by the owner.

The owner will give whatever advance notice the Authority may require to make the physical tap. The service from the main to the curb stop shall be installed by the owner in those locations where a main extension is required. Any work performed in any portion of the service, whether an original installation or not, shall be done by a New Jersey Licensed Plumber. The plumber shall provide a bond guaranteeing any defects in material and workmanship to the mains serviced, to the meter installation or any parts thereof which were made by him. The bond shall remain in effect for a period of not less than 2 years after issuance of the permit by the Authority including street opening permits by the Township, County or State. Road opening permits in Township streets shall be obtained from the Township. It is the owner's responsibility to connect to the curb stop and run the service at the owner's expense from the curb stop to the meter. The depth of the service shall be no less than 36". Applications for repair, replacement of services or new services shall be signed by the plumber and the owner of the premises connected to on forms provided by the Authority. The application shall include the sketch showing the location of the premises served. No curb stops will be located in driveways unless where unavoidable in the opinion of the Authority. The Authority shall inspect the service, service pipe, corporation cock, and curb stop prior to any backfilling; otherwise meter will not be installed and water will not be provided. In the event that a building is considered for abandonment or demolition, the Authority shall be notified in writing 30 days in advance thereof in order to shut off the service, in which case the Authority will remove the meter and discontinue service.

B. Existing Connections:

The Authority will maintain existing connections from the main up to the right-of-way of the street in which the main is located.

4.1 Size and Kind of Service Line

The Authority reserves the right to determine the size and kind of service from the main to the curb stop, or meter pit, and from the curb stop, or meter pit to the property to be served. Type K copper, flared underground-type, shall be used throughout for services up to and including three inches in diameter. For larger services, cast iron-cement line pipe meeting A.W.W.A. standards for Class 150 water pipe shall be used. The pipe from the curb stop, or meter pit, to the property shall be laid in a straight line at right angles to the curb line, within the building limits of structure to be served, and shall be at least four feet below the surface of the ground, when final grading of the property has been completed. If a customer wishes a connection of a larger size service line from the main to the curb stop, or meter pit than the Authority considers necessary, the customer shall pay the difference in cost between the larger size line and the size deemed necessary by the Authority. Such charge shall be in addition to any other charges imposed pursuant to these Rules and Regulations.

4.2 Separate Trench

No service pipe shall be laid in the same trench with gas pipe, drain or sewer pipe, or any other facility of any public service company, nor within three feet of any open excavation, vault, cesspool or septic tank; nor shall the location be in conflict with any sidewalk or driveway. All services shall comply with the Rules and Regulations of the Department of Environmental Protection, dated May 19, 1965 or the latest revision.

4.3 Renewal of Service Lines

Where the renewal of the service line from the main to the curb stop, or meter pit, is found to be necessary, the Authority will renew the service in the same location as previously used. If the property owner, or customer, for his own convenience, desires the new service line at some other location, and agrees to pay all expenses of such relocation, in excess of the cost of laying the service line in the same location as previously used, and cutting and disconnecting the old service line, the Authority will lay the new service line at the location desired.

4.4 Maintenance by Customer

All connections, service lines and fixtures furnished by the customer, shall be maintained by him in good order and all valves, meters and appliances furnished and owned by the Authority, and on the property of the customer, shall be protected properly and cared for by the customer. All leaks in the service or any other pipe or fixture in or upon the premises supplied, must be immediately repaired by the owner or occupant of the premises. The customer shall be responsible for notifying the Authority of the party engaged by said customer to do any maintenance work on the customer's service line, prior to work being commenced, and said party shall not backfill any trench until the work has been inspected and approved by the Authority's representative. Any work not acceptable shall be immediately removed and replaced by work which is acceptable.

4.5 Authority Not Responsible

The Authority shall in no event be responsible for maintaining any portion of the service line owned by the customer, or for damage done by water escaping therefrom; or from lines or fixtures on the customer's property; and the customer shall at all times comply with applicable regulations with respect thereto, and make changes therein, required by the reason of change of grades, relocation of mains or otherwise.

4.6 Property Supplied by Single Service Line

A service line from the curb stop, or a meter pit, to a property shall not supply more than one property, as generally described and classified below. But any such property, upon proper application of the owner, may be supplied by two or more meters, each of which, for billing purposes, shall be considered as being one customer account, and provided that the supply to each such meter has an individual control at or near the curb, viz:

- A. A dwelling house, either detached, or one side of a double house, or a house in a row of houses; provided, that a garage, a conservatory and similar structures accessory to the life of one family shall be considered as a portion of the dwelling.
- B. A industrial, or commercial, or manufacturing establishment.
- C. A building separated from adjacent buildings by a partywall or partywalls, and comprising apartments or stores or offices, or condominium townhouses, or any combination thereof.
- D. A detached building comprising apartments or stores or offices, or any combination thereof.

4.7 Single Service Line with Two or More Customers

Where two or more customers are now supplied through a single service line and any violation of the rules of the Authority occurs with respect to either or any of said customers, it shall be deemed a violation as to all, and unless said violation is corrected after reasonable notice, the Authority may take such action as can be taken for a single customer, except that such action will not be taken until a customer who has not violated the Authority's rules has been given a reasonable opportunity to attach his pipe to a separately controlled service connection.

4.8 Water Main or Service Line Crossing in Weymouth Township, Atlantic County, and New Jersey State Roadways.

Prior to the installation of water services or mains, either open-cut or boring, in any roadway within Weymouth Township, the proper street opening permit must be obtained. The conditions as outlined on the approved permit will also be considered as part of this section and will supersede this section in certain instances.

Generally the water services installed in these roadways will be bored or pushed. A casing will be required on water services up to 2" to prevent galvanic corrosion. Water services or water mains larger than 2" must conform to cast iron A-21.6 or 21.8 class 150 tyton joint cement lined ANSI 21.4 with mechanical joint fittings, ANSI 21.10-11 with the valves conforming to those specifications as provided for under Section 19. The above to be encased in steel pipe, schedule 80 and fabricated by electrically welding to size in accordance with AWWA C201-66 or latest revision. The inside diameter shall be of sufficient size to allow for deflection and bell ends.

The installation of borings larger than 2" will require the approval and inspection of the Engineer or other duly appointed entity for the Weymouth Township Municipal Utilities Authority.

4.9 Use of Water for Building Purposes

A supply of water for building or other special purposes, except on a lot or premises already supplied with a metered water connection, must be specially applied for and fees paid as specified in the Schedule of Rates. All applications for water for building purposes must be signed by the owner or his duly authorized agent, and shall be interpreted to mean that the water is to be used from a builder's hydrant, temporarily adapted with builder's meter.

4.10 Water Meters

A. All Water Services Shall be Metered

Each water service from curb stop, or meter pit, to a property shall be metered. The Authority reserves the right to determine the size and location of the meter and to determine whether certain types of uses, such as high density residential uses, shall be individually metered or mastermetered. The Authority shall install, own, and maintain 5/8" x 3/4" meters only. The meters shall be installed at an accessible location for replacement and reading purposes.

B. Cost For Meters

All water meters, except 5/8" x 3/4" meters, will be furnished by the Authority upon payment of a sum equivalent to the cost of the meter and yoke and shall be installed under the supervision of the Authority, and will remain the property of, and under the control of, the Authority, and will be accessible. No refunds shall be made for meter costs.

C. Location

After the applicant has provided space for the meter, which will be readily accessible and will provide protection for the meter, and has had the plumbing arranged to receive the meter, at a convenient point approved by the Authority, and so positioned as to meter and control the entire supply, the Authority will have the meter set. In cases where it is not practical to place the meter within a building, a brick, concrete or other approved meter box or pit, fitted with a suitable and approved type of iron cover, shall be built inside the property line by the customer. Water meter pits will not be installed for individual private homes. The size and dimensions of the pit or box shall be approved by the Authority, provide adequate access to the meter and permit its ready installation or removal. Meters shall be capable of being read on the outside of the premises being served. Above mentioned meter pits do not apply to home owners.

D. Valves Required

A wheel handled round way stop-cock or gate valve, shall be placed by the customer on the service line directly ahead of the meter, and a stop and waste-cock or valve on the outlet side of the meter.

E. Responsibility for Damage

Meters will be maintained by the Authority so far as ordinary wear and tear are concerned; but damage resulting from external causes due to the negligence of the customer, shall be paid for by the customer.

F. Cost of Reinstallation

The customer shall pay a charge for the reinstallation or changing of a meter when removed because of damage in any way due to the negligence of the customer. The reinstallation charge is in addition to the payment for the damages caused to the meter by the customer. Reinstallation charge shall be in accordance with the schedule of charges in effect at that time.

G. Minimum Charge

Each meter is installed subject to a fixed minimum quarterly charge in accordance with the adopted rate schedule, for which certain quantities of water will be furnished without additional charge. Such minimum charge shall be non-abatable for non-users of water, and non-curulative against subsequent consumption. In the case of fractional, period bills, covering less than a quarter, minimum charge and allowance shall be pro-rated.

H. Authority to be Notified When Meter Not Working

The customer shall immediately notify the Authority of injury to or non-working of the meter, as soon as known by the Customer.

I. Registration Conclusive

The quantity recorded by the meter shall be conclusive on both the customer and the Authority, except when the meter has been found to be registering inaccurately, or has ceased to register. In such cases, the quantity may be determined by the average registration of the meter when in proper working order.

J. Disputed Account

In the event of a disputed account involving the accuracy of a meter, such meter will be tested upon the request of the customer, in conformity with the provision of these Rules and Regulations. If when so tested, the meter is found to have an error in registration of four percent or more, the bills will be increased or decreased correspondingly.

K. Request Test

When a meter is removed, after installation, at the request of the customer for testing, the following rules shall apply:

The Authority shall, upon a written request of a customer, and if he so desires, in his presence or that of his authorized representative, make a test of the accuracy of his meter. When a customer desires, either personally or through a representative, to witness the testing of a meter, he may require the meter to be sealed in his presence before removal which seal shall not be broken until the test is made in his presence. If the meter so tested shall be found to be accurate within the limits specified in Subsection 4.10 (j), a fee determined from the schedule indicated below, shall be paid to the Authority by the customer requiring such test, but if the meter is found to be registering outside the limits specified in Subsection 4.10 (j), then the cost thereof shall be borne by the Authority when making such request, the customer shall agree to the basis of payment herein specified.

A report of such test shall be made to the customer and a complete record of such test shall be kept by the Authority. The amount of the fee shall be the cost borne by the Authority at the time of the test.

L. Meters on Private Water Supplies

In the event a residential, commercial or industrial establishment is served by a private water supply; the Authority reserves the right to require the owner to install a meter, of a type acceptable to the Authority. Said meter shall be for the use of the Authority in determining the potential for discharging excessive quantities of waste water to the public sanitary sewer system.

4.11 Public Fire Service

- A. Hydrant Location - Upon written instructions from duly authorized officials of the municipality to the Authority, fire hydrants will be installed in accordance with municipal requirements, provided that the size of the existing street main and surrounding distribution system and the available pressure of said main is, in the judgment of the Authority, sufficient to enable giving a proper service at the fire hydrant under normal and ordinary conditions. The filing with the Authority of copies of approved subdivision plans, showing fire hydrant locations, shall not be considered by the Authority to constitute written instructions from the duly authorized municipal officials, since such extensions must be made by the developers.
- B. Maintenance - All fire hydrants will be maintained by the Authority, unless maintained by the Township.
- C. Allowable Uses - Only persons authorized by the Authority shall take water from any public fire hydrant, except for fire purposes, or for use of Fire Department in case of fire. No public fire hydrant shall be used for sprinkling streets, flushing sewers or gutters, or for any use other than fire purposes, except with the written approval and consent of the Authority. Failure to do so will result in a \$1,000.00 charge.
- D. Change of Location - Whenever the Fire Commissioner desires a change in the location of any fire hydrant, the Authority, upon written notice to do so, will make such change at the expense of the municipality.
- E. Inspection - Upon written request of the Fire Commissioner, the Authority will make inspection at convenient times and at reasonable intervals to determine the condition of the fire hydrant; such inspection to be made by a representative of the Authority, accompanied by an authorized representative of the Fire Commissioners.

4.12 Private Fire Service

- A. Automatic Devices and Hydrants - For automatic sprinklers or other automatic fire service devices located inside of a building or buildings, a separate service line will be required, to be used exclusively for fire service. At the option of the customer, fire hydrants located outside of the building may be connected to the fire service line.

Each such separate service line shall be subject to the charges shown in the rate schedule. The Authority reserves the right to refuse approval for an application for automatic fire service where, in the judgment of the Authority, such service is not practical.

- B. Ownership and Location - All meters for private fire services shall first be approved by the Authority, but shall be furnished and installed by the customer. Meters will be set in an approved type of brick or concrete masonry meter vaults, adequately drained, located on the premises of the customer. The meter vaults are to be constructed and maintained at the expense of the customer. Meters and vaults shall at all times be accessible to the Authority, its officers and employees.

SECTION 5

RULES AND REGULATIONS FOR SEWER SERVICE

5.0 SEWER SERVICE CONNECTIONS

New connections to existing sewer mains will be at the expense of the applicant, (if approved by the Authority) including tapping, fittings, pipe, labor, and related materials. New laterals from the main to the curb vent shall be installed by the owner. The Authority will inspect sewer connections prior to any backfilling, otherwise service will not be provided. Connection to sewer mains from the main to the curb vent shall be owned and maintained by the Authority, not including the curb vent. Any work performed on any portion of the connection between the main and the curb shall be performed by a New Jersey Licensed plumber who shall provide a bond guaranteeing any defects in materials and workmanship as set forth under water services. All road opening permits shall be secured as required from the State, County or Township. In the event that a building is considered for abandonment or demolition, the Authority shall be notified in writing thirty days in advance thereof in order to shut off the service, in which case the Authority will discontinue service.

Connections to existing sanitary sewers, unless otherwise approved by the Authority shall be made with saddles or folding in of "Y's" on asbestos cement pipe. Under no condition will projections be permitted inside the main. Where the size of the connections is in excess of 6", the connection shall be made with a manhole. Connections made below ground water shall be inspected by the Authority and the inspection shall be continuous at the expense of the Owner. There shall be no direct payment made for this inspection service for the first four hours, but thereafter the rate shall be \$20.00 per hour paid for by the plumber.

No plumber or any other person shall perform any work on any sewer or connection without the consent of the Authority or its authorized representative, otherwise the plumber or other persons performing the work shall not be paid for any expenses incurred in performing the work nor shall the owner be reimbursed for any expense paid the plumber or any other person in connection with any work performed between the curb and the main. The plumber or other person prior to commencing any work on the connection between the main and the curb, shall submit a written request for inspection by the Authority. No connection less than 4" in diameter will be permitted.

5.1 Size and Kind of Service Lateral

The Authority reserves the right to determine the size and kind of the service lateral from the main to the curb line, from the curb line to the property to be served, or from the main in the right-of-way to the property to be served. Laterals of all sizes shall be constructed of medium strength cast iron soil pipe, A.S.T.M. Standard Specification C-13, with coulted plastic joints of the type known as "Tylox" or equal, or PVC pipe, SDR 35 with elastomeric joints.

The service lateral from the curb to the property including the sewer vent shall be furnished, installed and maintained by the owner of the property, shall be laid in a straight line from the point of connection to the main, where the main is in a right-of-way, or from the end of the Authority constructed service lateral, to the structure to be served and where possible shall be at least four feet below the surface of the ground when final grading of the property has been completed. That portion of the service lateral and sewer vent installed and maintained by the owner shall be installed in accordance with the Township Plumbing Code, shall be inspected and approved by the Township Plumbing Inspector prior to backfilling the trench. Any construction not approved shall be immediately removed and reconstructed in an approved manner.

5.2 Separate Trench

No service lateral shall be laid in the same trench with any gas pipe, water service, or any other facility of any public service company, nor within three feet of any open excavation, vault, meter pit; nor shall the location be in conflict with any sidewalk or driveway. All service shall comply with the Rules and Regulations of the State Department of Environmental Protection, dated May 19, 1965 or the latest revision.

5.3 Renewal of Service Lateral

Where the renewal of the service lateral from the main to the curb is found to be necessary, the Authority will renew the service in the location as previously used. If the property owner as customer, for his own convenience, desires the new service lateral at some other location and agrees to pay all expenses of such relocation, in excess of the cost of laying the service line in the same location as previously used, and cutting and disconnecting the old service lateral, the Authority will lay the new service lateral at the location desired.

5.4 Maintenance by Customer

All connections, service laterals, sewer vents and fixtures furnished by the customer, shall be maintained by him in good order, and all piping and connections furnished and owned by the Authority and on the property of the customer, shall be protected properly and cared for by the customer. All leaks in the service lateral or any other pipe fixture in or upon the premises served, must be repaired immediately by the owner or occupant of the premises. The customer shall be responsible for notifying the Authority of the party engaged by said customer to do any maintenance work in the customer's service lateral, prior to work being commenced, and said party shall not backfill any trench until the work has been inspected and approved by the Authority's representatives. Any work not acceptable shall be immediately removed and replaced by work which is acceptable. The connection or service lateral from the curb to the main shall be maintained by the Authority. The first lateral installed shall be the only lateral to the property maintained by the Authority. All additional laterals shall be maintained by the applicant-owner.

5.5 Authority Not Responsible

The Authority shall in no way be responsible for maintaining any portion of the service lateral owned by the customer, or for damage done by sewage escaping therefrom; or for lines or fixtures on the customer's property; and the customer shall at all times comply with applicable municipal regulations with respect thereto, and make changes therein, required by reason of changes of grade, relocation of mains or otherwise.

5.6 Property Served by Single Service Lateral

A service lateral from the curb, or the main in a right-of-way to a property, shall not serve more than one property, but any such property upon application of the owner, may be served by two or more laterals, such of which, for billing purposes, shall be considered as being one customer account.

5.7 Single Service Lateral with Two or More Customers

Where two or more customers are now served through a single service lateral, any violation of the rules of the Authority, with respect to either or any said customer, shall be deemed a violation as to all, and unless said violation is corrected after reasonable notice, the Authority may take such action as may be taken for a single customer, except that such action will not be taken until a customer who has not violated the Authority's rules has been given a reasonable opportunity to connect his pipe to a separately controlled service lateral.

5.8 Prohibited Connections

Under no circumstances will any of the following be connected to the sanitary sewer, either directly or indirectly, viz:

- A. Foundations underdrains
- B. Floor drain, area drain or yard drain
- C. Rain conductor or downspout
- D. Grease pit
- E. Air conditioning equipment
- F. Storm water inlets or catch basins
- G. Drains from piece of equipment or manufacturing process, except when specifically authorized under the provisions of these rules and regulations.

5.9 Special Connections

Service laterals to public buildings, churches, apartments, commercial establishments, and industrial establishments, shall be installed to conform to detailed plans and specifications as approved by the Authority Engineer.

5.10 Special Precautions in Wet Ground

Where ground water is normally above the invert elevation of the service lateral, "Tyton" joints, or approved equal, or cast iron soil pipe with properly caulked lead joints, shall be used in construction of service laterals. Where the bottom is soft and yields, the Authority Engineer reserves the right to require that the service be laid in partial or total concrete encasement. Junctions of two different types of pipe, shall at the option of the Authority Engineer be required to be constructed in concrete of a mix determined by the Authority Engineer.

5.11 Agreement Required for Acceptance of Industrial Wastes

The Authority will accept industrial wastes into the sanitary sewer system upon execution of a formal written Agreement and subject to the provisions appearing in said Agreement and the rules stated hereinafter and in conformance with an Agreement in existence and executed between the Atlantic County Utilities Authority and the Weymouth Township Municipal Utilities Authority. Where there is a difference as to which is the stringent form that is the provisions of these rules and regulations, those requirements which are most stringent in the opinion of the Authority shall apply. Where any Federal Categorical Pretreatment Standard applicable to a particular industrial subcategory is more stringent than limitations imposed under these rules and regulations for sources in that subcategory, the Federal Standard shall supercede the limitations under these rules and regulations. Affected industrial users shall comply with the applicable standard(s) by the compliance deadlines specified in 40 CFR 403.6 (b). All industrial users subject to Federal

Categorical Pretreatment Standards shall, at a minimum comply with the reporting requirements contained in 40 CFR 403.12. The agreement will set out in detail the characteristics of the water, the flow conditions which shall govern and the conditions with respect to the physical connection or connections. It will be the policy of the Authority to consider each application on its own merits, and to establish specific conditions applicable to the particular situation, for each agreement. No connection shall be made prior to execution of the agreement. Any industrial user as defined by N.J.A.C. 7:14 A-1 et seq., shall obtain a State NJPDES/SIU permit prior to commencing discharge of wastes into the Authority's sewer system, as outlined in Section 6.

5.12 Special Application

Prior to approving an application for a connection involving the acceptance of industrial wastes, the Applicant shall submit complete data with respect to the following:

- A. Average, maximum and minimum rates of flow to be expected daily and seasonally.
- B. Flow diagram, showing points of application of chemicals, type and quantity of each chemical used per day and per shift, a schedule of operations, expected chemical characteristics of the untreated wastes, and the point or points of connection to the sewerage system. The normal situation will require the separation of, and separate points of connection for, domestic sewage and industrial wastes from each industrial establishment.

5.13 Prohibited Wastes

Wastes containing the following substances or possessing the characteristics listed below, will not be accepted:

- A. Any liquid or vapor having a temperature higher than 104° F (40° C) or in excess of that permitted by pretreatment standards.
- B. Any liquid containing fats, wax, grease or oils, whether emulsified or not, in excess of 100 mg/liter of solvent soluble materials or containing substances which may solidify or become viscous at temperatures between 32 and 150° F (0° and 65° C).
- C. Any wastewater that contains more than two (2) parts per million by weight any of the following gases:
 1. Hydrogen chloride
 2. Sulfur dioxide
 3. Oxides of nitrogen

- D. Any residues from petroleum storage, refining or processing, waste fuels, lubricants or solvents.
- E. Any wastewater containing any liquids, solids or gases which by reason of their nature or quantity are, or may be, sufficient either alone or by interaction with other substances to create an explosive, flammable or combustible atmosphere in any part of the Local Sewer System. At no time shall two (2) successive readings on an explosion hazard meter, at the point of discharge into the sewer system, be more than five (5%) percent nor any single reading over ten (10%) percent of the Lower Explosive Limited (L.E.L.) of the meter.
- F. Any solid or viscous substance in quantities or of such size capable of causing obstruction to the flow in sewers such as, but not limited to, mud, straw, metal, rags, glass, tar, plastics, wood and shavings.
- G. Any solid or viscous substance in quantities of such size capable of causing an interference with the proper operation of the Local Sewer System such as, but not limited to, ashes, cinders, sand, feathers, fleshings, entrails, paper or plastic containers, etc.
- H. Any garbage that has not been properly shredded.
- I. Any waste having a pH lower than 5.0 or higher than 9.0 or having any other corrosive property capable of causing damage or hazard to structures, equipment and personnel of the Authority.
- J. Any radioactive waste or isotope of such half-life or concentration as to be in excess of that permitted by appropriate regulatory agencies having control over their use or in such quantity as to cause damage or hazard to structures, equipment and personnel of the Authority.
- K. Any waste containing noxious or malodorous solids, liquids or gases, which, either single or by interaction with other wastes, are capable of creating a public nuisance or hazard to life, or are or may be sufficient to prevent entry into a sewer for its maintenance and repair.
- L. Any material which exerts or causes:

1. Unusual concentration of inert suspended solids (such as, but not limited to, Fuller's Earth, lime slurries and lime residues) or of dissolved solids (such as, but not limited to, sodium chloride and sodium sulfate).
 2. Excessive discoloration (such as, but not limited to, dye solutions and vegetable tanning solutions) which cannot be removed by the wastewater treatment plant.
 3. Unusual BOD, COD or chlorine requirements in such quantities as to constitute an unacceptable load on the wastewater treatment works.
 4. Any unusual concentration or flow of any given constituent which for any period of duration longer than fifteen (15) minutes exceeds more than five (5) times the average twenty-four (24) hour concentrations or flow rates during normal operation.
- M. No person shall discharge to the Local Sewer System any liquid containing toxic solids, liquids or gases in sufficient quantity, either single or by interaction with other wastes, to injure or interfere with any wastewater treatment process, constitute a hazard to humans or animals, create a public nuisance, prevent the attainment of effluent limitations as imposed by Regulatory Agencies, preclude the selection of the most cost effective alternative for wastewater treatment or sludge disposal, or create any hazard in the effluent of the wastewater treatment plant or the receiving waters are hereby prohibited.
- N. The concentration in wastewater of any of the following substances shall be limited to the stated maximum concentrations in order to be acceptable for discharge to the Local Sewer System:

<u>Permissible Concentration</u>	<u>Maximum milligrams/liter</u>
Arsenic (as AS)	4.0
Boron (as Bo)	1.0
Chromium (total)	5.0
Chromium (hexavalent)	2.0
Copper (as Cu)	1.0
Cyanide (total)	1.0
Iron (as Fe)	15.0
Lead (as Pb)	0.1
Nickel (as Ni)	1.0
Zinc (as Zn)	5.0
Cadmium (as Cd)	2.0
Phenol	0.1
Mercury (as Hg)	0.01
MBAS	10.0
Total Solids	5,000.0
Silver (as Ag)	0.05

O. Any vapor or steam

5.14 Grease, Oil and Sand Separators

When, in the opinion of the Authority Engineer, grease, oil, and sand interceptors, or oil reclaimers are required, they shall be provided and maintained at the expense of the owner, in continuously efficient operating condition. Grease and oil interceptors shall be constructed of impervious materials, capable of withstanding abrupt and extreme changes in temperature. They shall be watertight, substantially constructed and equipped with readily removable access covers. Where deemed necessary cold water sprays shall be installed. The design and pertinent data shall be submitted to the Authority for review and approval, prior to construction or installation. Separators must be constructed entirely on the property of the owner.

5.15 Preliminary Treatment

- A. The Authority reserves the right to require preliminary treatment, where the chemical characteristics of the proposed industrial wastes, in the opinion of the Authority Engineer, or in the opinion of the Department of Environmental Protection, make such preliminary treatment desirable or mandatory. Some of the characteristics which may dictate preliminary treatment are listed below:

1. 5 day B.O.D. in excess of 250 p.p.m.
 2. Suspended solids in excess of 250 p.p.m.
 3. Average daily flow in excess of 10,000 gallons per day.
 4. Presence of arsenic, barium, cadmium, chloride, chromium, copper, cyanide, flouride, iron, lead, magnesium, manganese, nickel, nitrate, selshium, sulfate, zinc, or pH values outside the acceptable limits described in subsection 5.14, J.
- B. In such instances where it is agreed that the industrial waste will be received following preliminary treatment, drawings and specifications shall be submitted for approval of the Authority Engineer showing all pertinent details of the construction proposed to accomplish the treatment, to include details of the indicator recorder-register type of fluid meter, and housing to be used, to meter the flow of industrial wastes, and also details of the control manhole to be constructed on the industrial wastes connection within the sidewalk area. The control manhole shall be provided with adequate access manhole covers of approved type, through which access shall be possible to Authority personnel at all times. Drawings, specifications, reports, etc., shall be submitted in quadruplicate, and shall be prepared and sealed by a professional engineer registered in the State of New Jersey.
- C. Where preliminary treatment facilities are required, they shall be provided and continuously maintained in an effectively operating condition at all times, at the expense of the industry.
- D. Each industry connected to the Authority sewer system shall be responsible for maintaining a quality of effluent from their premises, which conforms to the provisions established in their agreement with the Authority. Sampling and analysis shall be done to conform with accepted practice, and in accordance with the current edition of "Standard Methods for the Examination of Water, Sewage and Industrial Wastes."
- E. The cost of preparing and submitting this data for consideration by the Authority, shall be borne by the industry. Likewise, the cost of sampling and analysis to determine compliance with the terms of the agreement, shall be borne by the industry although conducted by the Authority, or its duly authorized representatives.

- F. Industries permitted to connect to Authority sewers, even though not initially being required to provide preliminary treatment, may be required to provide a control manhole and/or meter, as described in Section B above.

5.16 Enforcement Procedures

- A. Notification of Violation - Whenever the Local Authority finds that any person has violated or is violating this resolution and the prohibitions, limitations or requirements contained herein, he may serve upon such Person a written notice stating the nature of the violation and providing a reasonable time, not to exceed thirty (30) days, for the satisfactory correction thereof.
- B. Legal Action - Any discharge in violation of the substantive provisions of this resolution or an Order of the Authority shall be considered a public nuisance. If any person discharges sewerage, industrial wastes or other wastes into the local sewer in violation of this ordinance or any Order of the Authority, the Authority Solicitor shall commence an action for appropriate legal and/or equitable relief in an appropriate court of this municipality or the municipality in which this Authority is located. In the event such action is commenced by the Authority Solicitor, the payer for relief shall include a claim for all costs of such action, including reasonable attorney fees. In the event the Authority prevails in such legal action, such costs, including reasonable attorney's fees, shall be paid by the person against whom the proceeding has been commenced.
- C. Penalties - Any person who shall violate any Provision of this resolution or fail to comply therewith shall severally, for each and every violation and non-compliance, forfeit and pay a penalty not to exceed the sum of FIVE HUNDRED (\$500.00) DOLLARS. This imposition of the foregoing penalty shall not bar the right of the Authority to specifically enforce the provisions of this resolution.

Any violation of this resolution shall be considered a distinct and separate violation for each and every day that the violation continues.

- D. The Authority reserves the right to cancel the agreement, upon one year's written notice, in the event of repeated failure to comply with the terms of the agreement, or the rules and regulations of the Authority.

5.17 Industrial Waste Meters

Where the industry provides its own water supply, entirely separate from that supplied by the Authority, or provides from its own sources, a portion of the water consumed on the premises, which eventually finds its way into the sewerage system of the Authority, the provisions of the Schedule of Rates will apply. This does not relieve the industry from the requirement to furnish, install and maintain a meter of the indicator-register-recorder type, to measure this discharge of industrial wastes, as described in Subsection No. 5.15b. The meter will be approved by the Authority but supplied by the customer with the cost of the said meter and installation to be borne by the industry. All cost of furnishing, installing and maintaining the industrial waste flow meter will be borne by the industry and shall be readily accessible by Authority personnel.

5.18 Admission to Property

Whenever it shall be necessary for the purposes of this resolution, the officers and agents of the WTMUA, upon the presentation of credentials, may enter upon any property or premises at reasonable times for the purpose of (a) copying any records required to be kept under the provisions of this ordinance, (b) inspecting any monitoring requirement or method, and (c) sampling any discharge of wastewater. The officers and agents of the WTMUA may enter upon the property at any hour under emergency circumstances.

5.19 Protection from Accidental Discharge

Each industrial user shall provide protection from accidental discharge of prohibited materials or other regulated wastes. Facilities to prevent accidental discharge of prohibited materials shall be provided and maintained at the user's own costs and expense. Detailed plans showing facilities and operating procedures to provide this protection shall be submitted to the Authority for review, and shall be approved by the Authority before construction of the facility. Review and approval of such plans and operating procedures shall not relieve the industrial user from the responsibility to modify his facility as necessary to meet the requirements of this resolution.

5.20 Reporting of Accidental Discharge

If, for any reason, a facility or user does not comply with or will be unable to comply with any prohibition or limitation in this ordinance the facility responsible for such discharge shall immediately notify the Authority so that corrective action may be taken to protect the treatment system. In addition, a written report addressed to the Authority detailing the date, time and cause of the accidental discharge, the quantity and characteristics of the discharge and the corrective action taken to prevent future discharges, shall be filed by the responsible industrial facility within five (5) days of the occurrence of the non-complying discharge.

5.21 Refusal of Discharge

Nothing under this Article shall be construed to reduce in any manner the power of the Authority to refuse to accept any discharge if in its' opinion, there is not compliance with the provisions of any Section of this ordinance.

5.22 Disputed Volumes and/or Pollutant Concentration

In the event that the volume and/or pollutant concentration of the waste discharged to the Local Sewer System as determined under Sections 5.17 and 5.15, D of this Article is disputed by a user, a program of resampling and gaging with subsequent chemical determination may be instituted as follows:

- A. The user may submit a written request for resampling and gaging of the waste to the Authority. Upon receipt of such request, the Authority will conduct the necessary test at user's expense. The user shall confer with representatives of the Authority in order that agreement may be reached as to the various factors which must be considered in a new sampling program, or
- B. The user may, at his own expense, employ a consultant or agency of recognized professional standing to conduct a resampling and reanalysis program, under the direction of the Authority and for a period of time to be specified by the Authority.

The results of the resampling and the reanalysis shall be considered to be the current analysis of the user's waste. In all cases, the determination of the Authority, whether or not modified after resampling and reanalysis, as provided for in this Section, shall be final as regards volumes or pollutant concentrations.

SECTION 6

INDUSTRIAL WASTE DISCHARGE PERMITS

6.0 WASTEWATER DISCHARGE PERMITS REQUIRED

Any new source Significant Industrial User (SIU), as defined by NJSA 7:A-1 et seq., shall obtain a State NJPDES/SIU Permit prior to commencing a discharge into the treatment works. All existing industrial users connected to or discharging into any parts of the Local Sewer System must obtain a State NJPDES/SIU Permit within ninety (90) days of the date of final adoption and promulgation of these rules and regulations.

6.1 Permit Application

Users seeking a State NJPDES/SIU Permit shall first complete and file with the Authority an application on the form prescribed by the State accompanied by the applicable local review fee. In support of this application, the user shall assure that the following information is provided if not requested on the State form:

- A. Name, address and SIC number of applicant.
- B. Volume of wastewater to be discharged.
- C. Wastewater constituents and characteristics including but not limited to, those set forth in Section 5 of these rules and regulations, as determined by an analytical laboratory of recognized professional standing.
- D. Time and duration of discharge.
- E. Average and heavy peak wastewater flow rates including daily, monthly and seasonal variations, if any.
- F. Site plans, floor plans, mechanical and plumbing plans and details to show all sewers and appurtenances by size, location and elevation.
- G. Description of activities, facilities and plant processes on the premises including all materials and types of materials which are, or could be, discharged.
- H. Each product produced by type, amount and rate of production.
- I. Number and type of employees and hours of work.

- J. Any other information as may be deemed by the Authority to properly determine the nature of the waste to be discharged.

The Authority will evaluate the data furnished by the user and may require additional information. After evaluation and acceptance of the data furnished, the Authority may forward same to the State for processing.

6.2 Permit Conditions

Wastewater discharge permits shall be expressly subject to all provisions of this resolution and all other rules and regulations established by the State, and the Authority. The conditions of wastewater discharge permits shall be uniformly enforced in accordance with this resolution, and applicable state and federal regulations. Permit conditions may include the following:

- A. The average and maximum wastewater constituents and characteristics.
- B. Limits on rate and time of discharge or requirements for flow regulations and equalization.
- C. Requirements for installation of inspection and sampling facilities, and specification for monitoring programs.
- D. Requirements for maintaining and submitting technical reports and plant records relating to wastewater discharges.
- E. Daily average and daily maximum discharge rates, or other appropriate conditions when pollutants subject to limitations and prohibitions are proposed or present in the user's wastewater discharge.
- F. Compliance schedules.
- G. Other conditions to ensure compliance with this resolution.

6.3 Duration of Permits

Permits shall be issued for a period specified by the State or the Authority. The terms and conditions of the permit may be subject to modification and change by the Authority during the life of the permit, as limitations or requirements as identified in Section 5 are modified. A user shall be notified of proposed changes in his permit at least thirty (30) days prior to the effective date of change. Any changes or new conditions in the permit shall include a reasonable time schedule for compliance.

6.4 Transfer of a Permit

Permits are issued to a specific user for a specific operation. An Industrial Waste Discharge Permit shall not be reassigned or transferred subject to having his permit revoked. Violations subjecting a user to possible revocation of his permit include, but are not limited to the following:

- A. Failure of a user accurately to report the wastewater constituents and characteristics of his discharge;
- B. Failure of the user to report significant changes in operation or wastewater constituents and characteristics;
- C. Refusal of reasonable access to the user's premises for the purpose of inspection or monitoring; or
- D. Violation of conditions of the permit.

6.5 Pretreatment Requirements

Any industrial user requiring pretreatment is subject to the provisions as set forth in Section 5.15 of this resolution.

CONSTRUCTION DETAILS

WATER

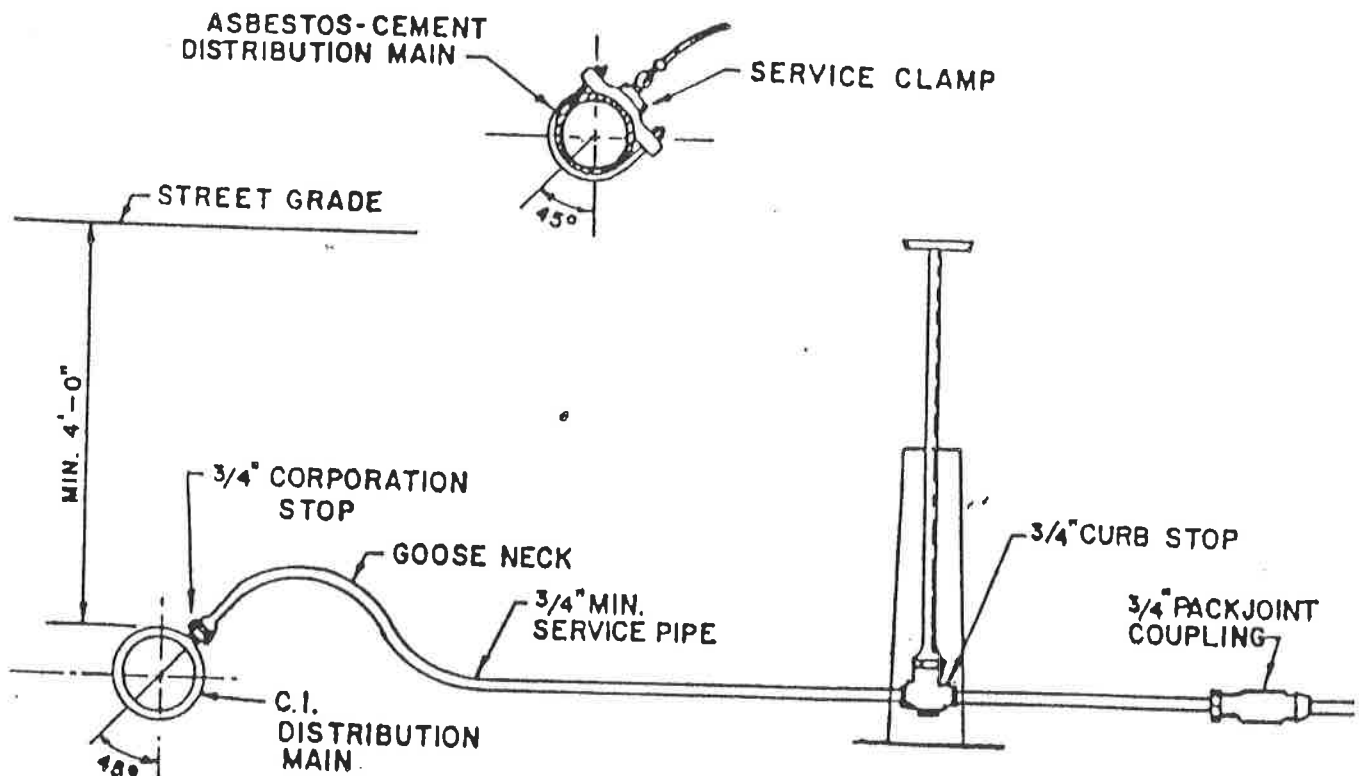

NOTES:

1. Service pipe to be 3/4" minimum "K" Copper.
2. Corporation cock to be 3/4" packjoint type similar to Ford F1000 or approved equal.
3. Curb stop to be 3/4" packjoint type similar to Ford B44-333 or 266-333 or approved equal.
4. Couplings to be 3/4" packjoint type similar to Ford C44-33 or approved equal.
5. Location of curb stop and box to be in planter area or one (1) foot on resident's side of proposed sidewalk and never outside of street R.O.W.
6. No deviation from these specifications shall be made without approval of the Weymouth Township Municipal Utilities Authority (MUA).
7. No connection will be back-filled until written approval is made by the Weymouth Township MUA.
8. Violators will be required to expose the work for inspection before approval will be granted.
9. All new applicants for water service will be provided with an approved remote read-out meter. No substitutions will be permitted unless approved by the Weymouth Township MUA.

TYPICAL WATER SERVICE HOUSE CONNECTION

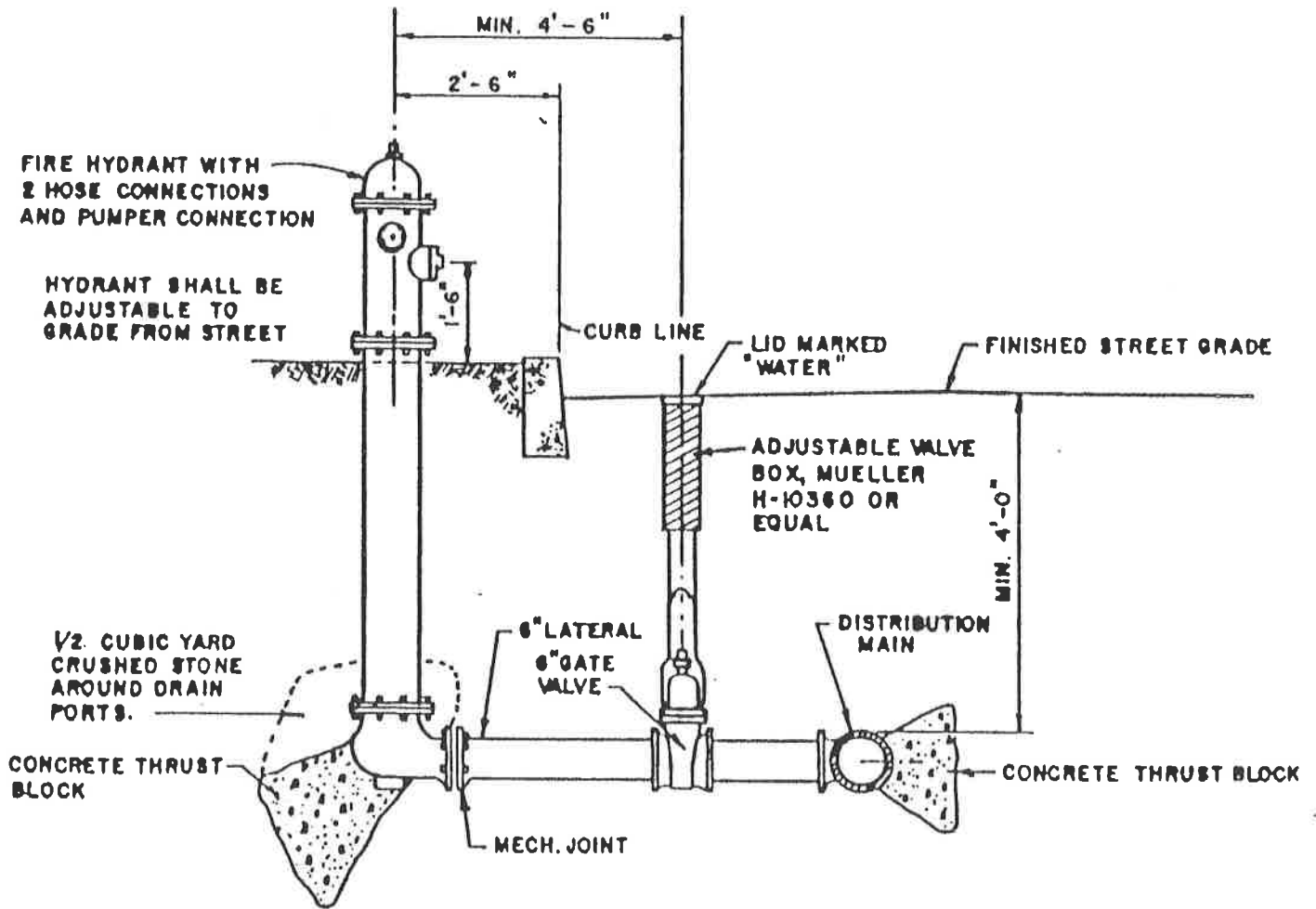

FIRE HYDRANT ASSEMBLY

SCALE: $\frac{3}{8}'' = 1'-0''$

5/2" MIN. UP TO 12" PIPE
7" MIN 12" PIPE AND UP

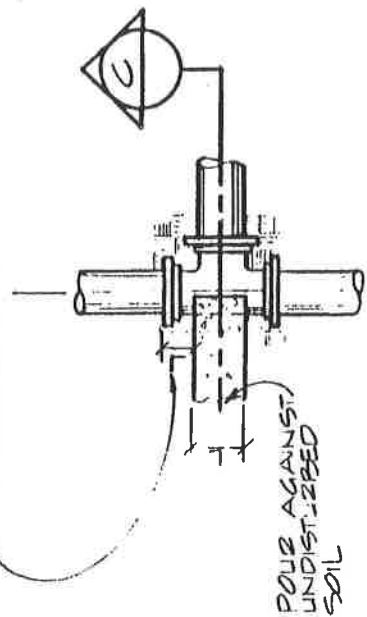

POUR AGAINST
UNDISTURBED
SOIL

A PLAN

3000 PSI
CONG.

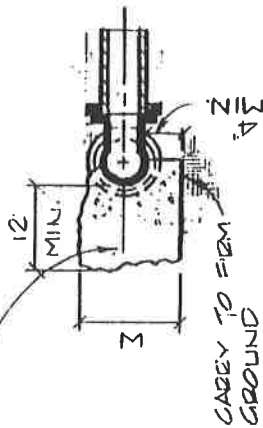

CARRY TO FIRM
GROUND

C SECTION

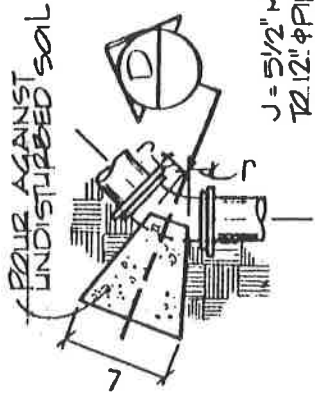

J = 5/2" MIN. UP
TO 12" PIPE, 7"
MIN. 12" PIPE & UP

B PLAN

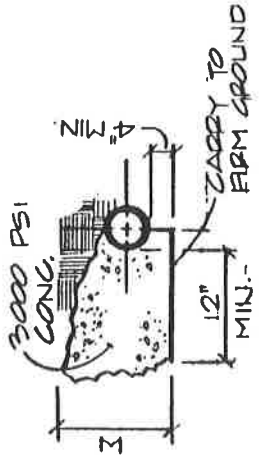

CARRY TO FIRM
GROUND

D SECTION

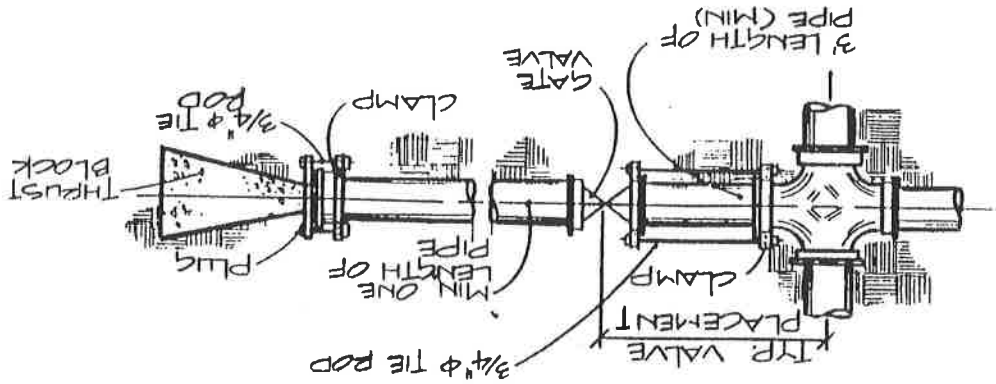

E DETAIL OF TEE

NOT TO SCALE

F DETAIL OF BEND

NOT TO SCALE

*NOTE:

DRAWINGS TO BE USED WITH
THRUST BLOCK MONOGRAPH ONLY!

THRUST BLOCK DETAIL

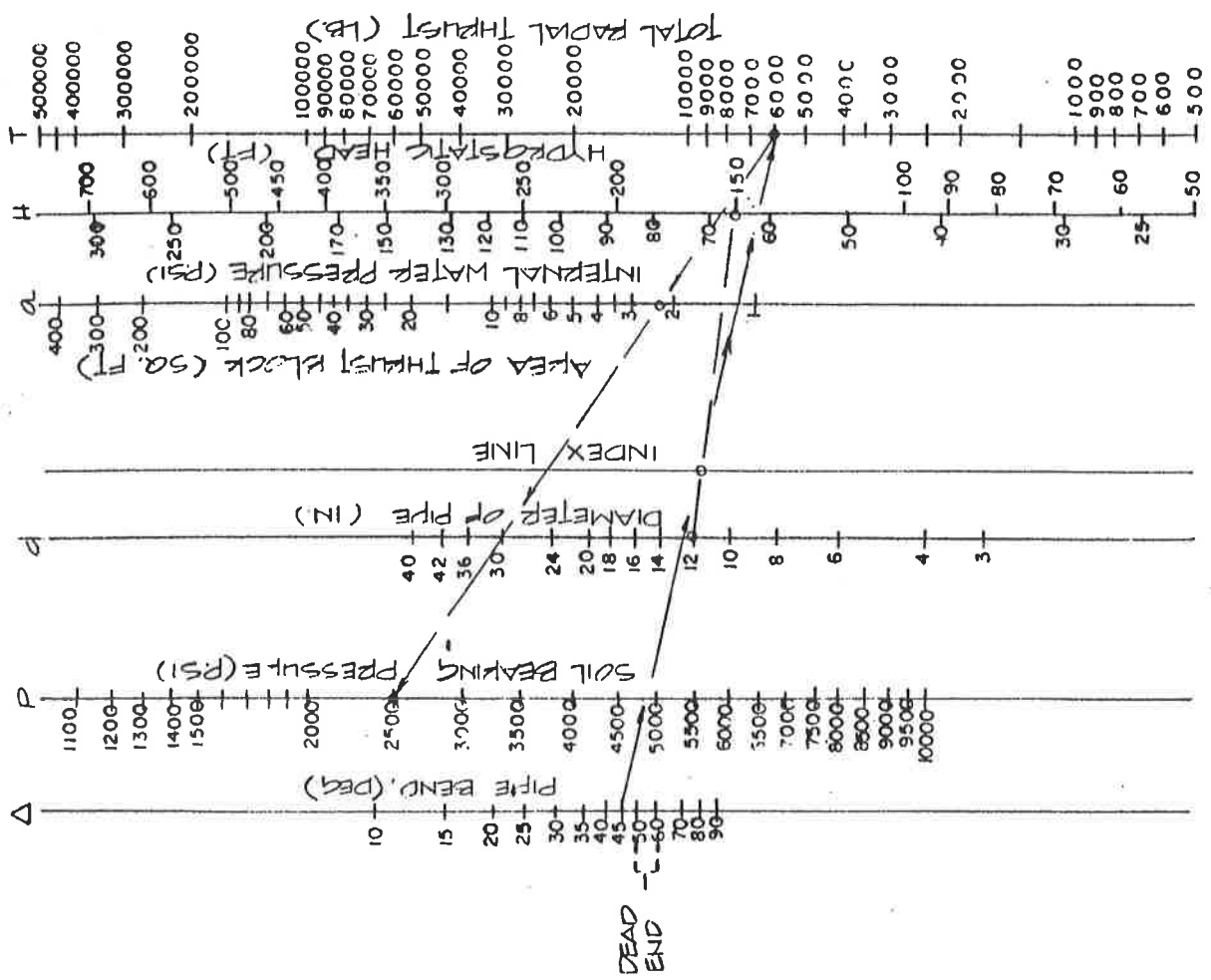

LEGEND

- H = HYDRAULIC HEAD (FT.)
- d = DIAMETER OF PIPE (IN.)
- Δ = PIPE BEND (DEGREE)
- T = TOTAL RADIAL THRUST (LB.)
- P = SOIL BEARING PRESSURE (P.S.I)
- a = AREA OF THRUST BLOCK (SQ. FT.)

NOTE:

EXAMPLE SHOWN ON GRAPH IS FOR A 45° PIPE BEND SUBJECTED TO 150' HYDROSTATIC HEAD.

NOMOGRAPH FOR BEARING AREA OF THRUST BLOCKS

SEWER

NOTE:
 LOCATION OF SERVICE CONNECTION & CLEANOUT SHALL BE DETERMINED IN THE FIELD TO COMPLY WITH REQUIREMENTS OF PROPERTY OWNER & M.U.A.

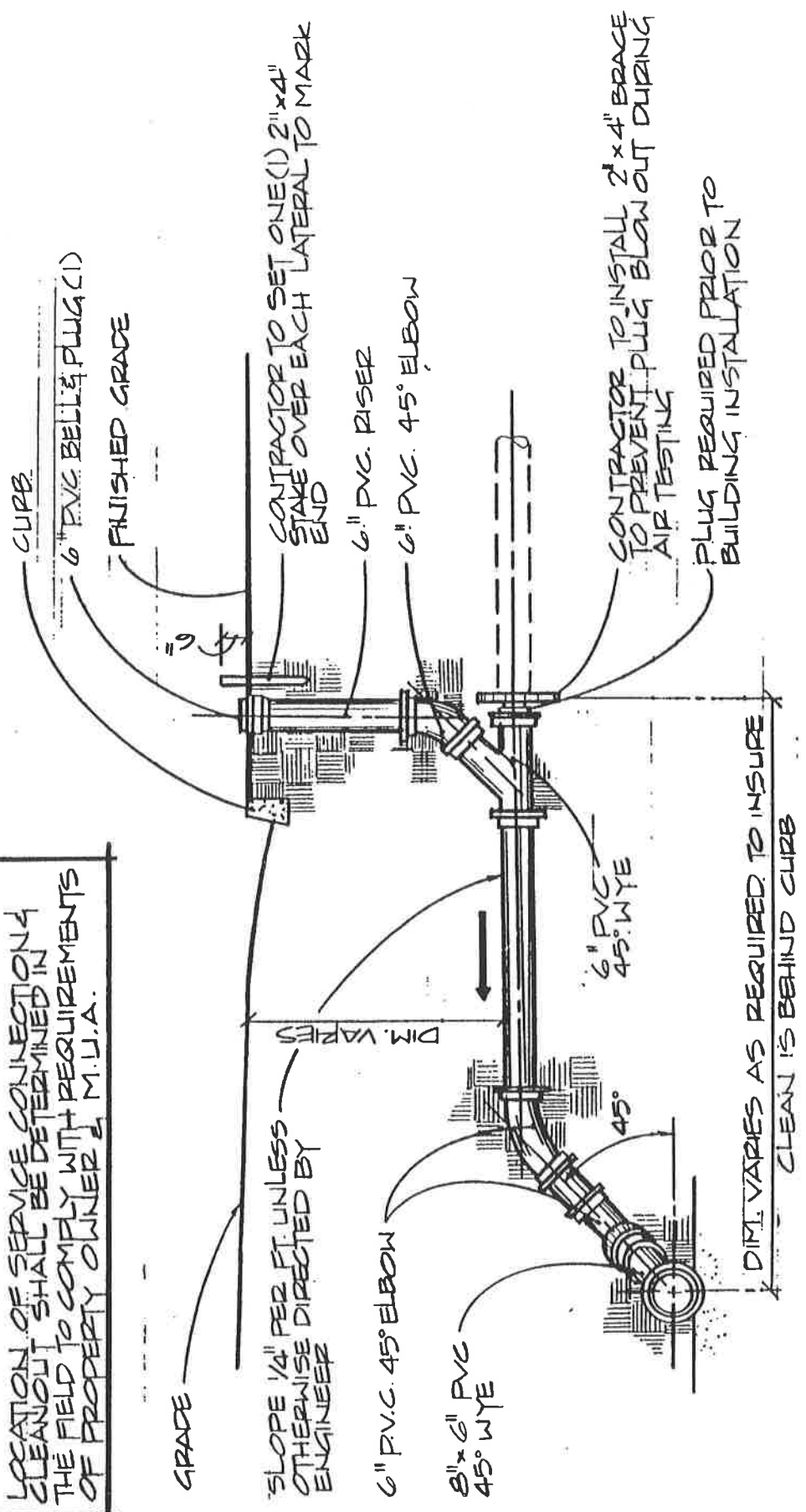

NOTES:

1. PLUG TO CONTAIN MAGNETIC MATERIAL SO THAT IT MAY BE LOCATED WITH A METAL DETECTOR
2. CLEANOUT SHALL NOT BE LOCATED IN SIDEWALKS OR DRIVEWAY

TYPICAL SANITARY SERVICE LATERAL CONNECTION

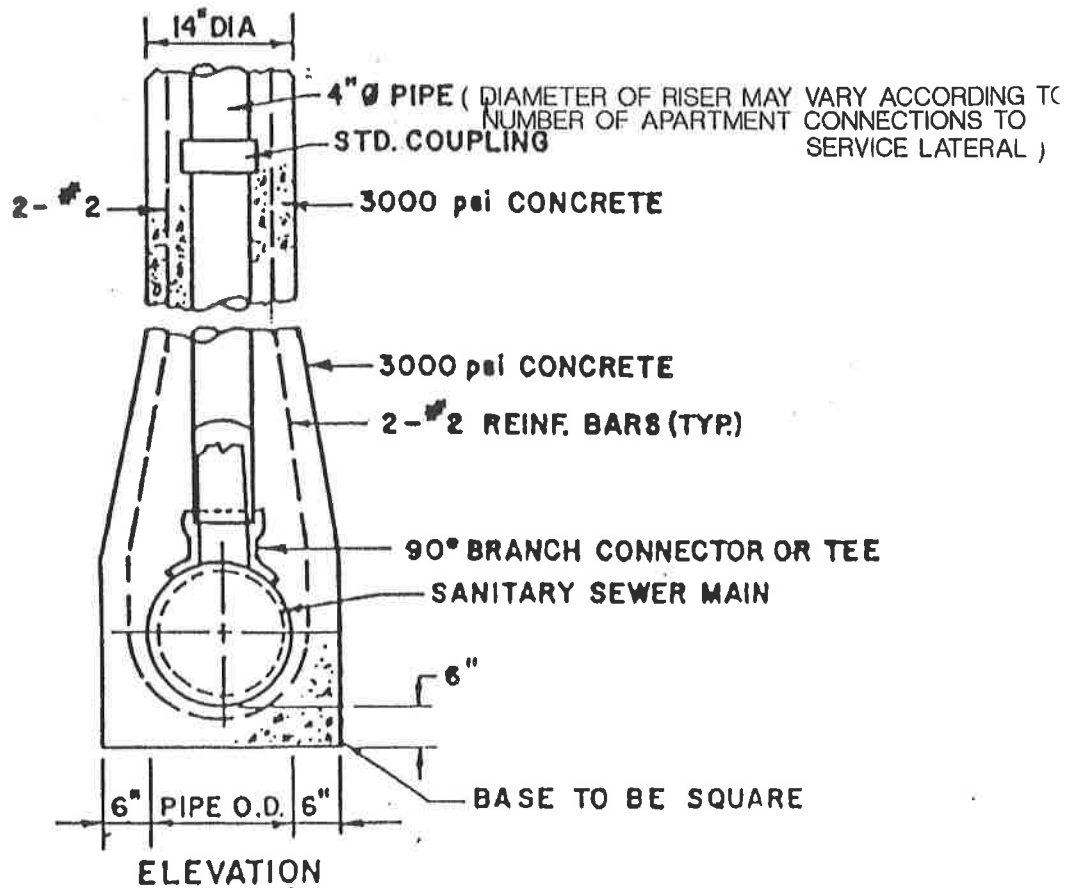
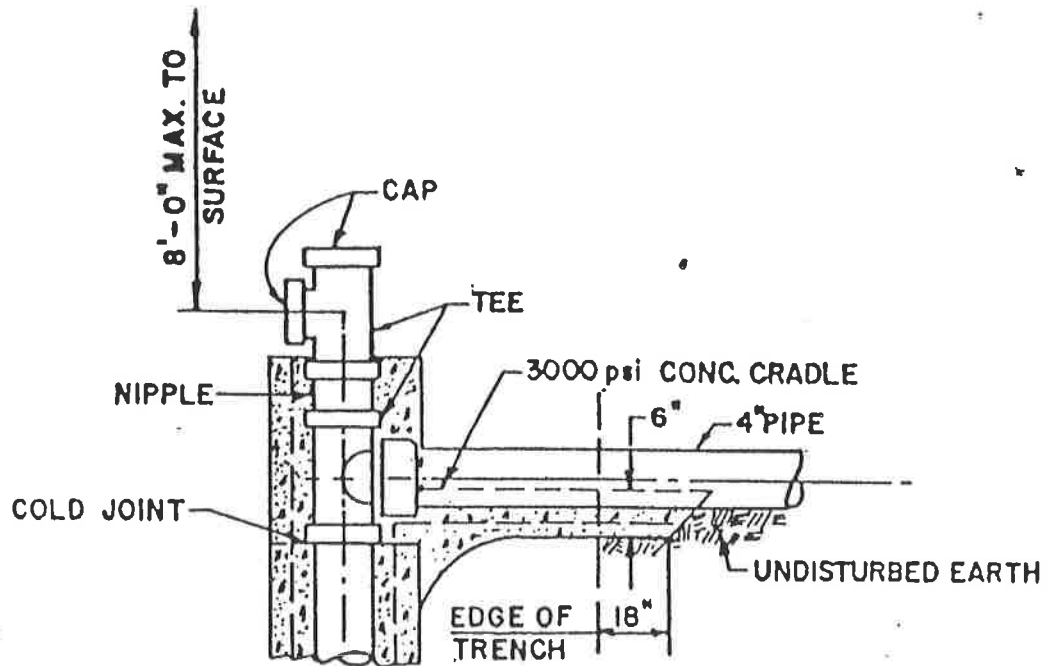

DEEP HOUSE CONNECTION LATERALS

SCALE: NONE

DEEP HOUSE LATERAL CONNECTION

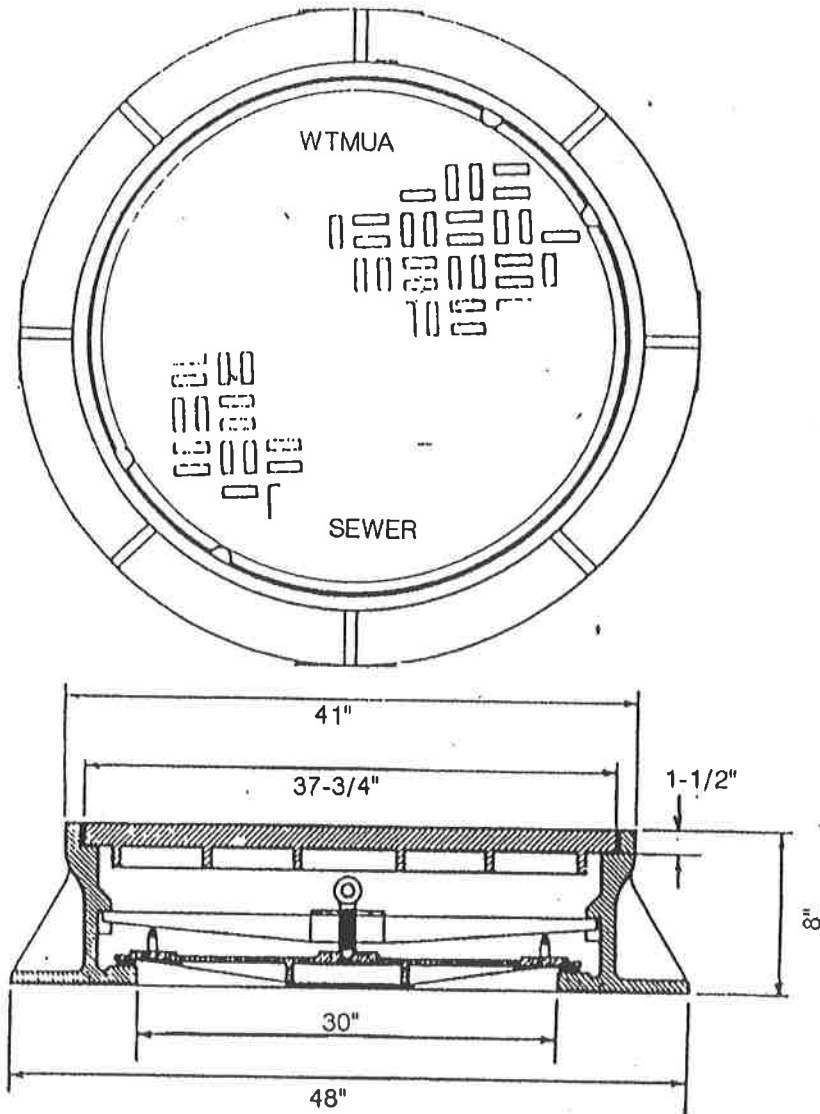

NOTES:

- A. CASTING SHALL BE DIP COATED IN ASPHALTUM PAINT.
- B. BEARING SURFACE OF FRAME AND COVER SHALL BE MACHINED.
- C. COVER SHALL BE SUPPLIED WITH 1-1/2" HIGH BLOCK LETTERING, RAISED.
- D. CAMPBELL FOUNDRY PATTERN NUMBER 1541 OR APPROVED EQUAL.

STANDARD MANHOLE FRAME AND COVER

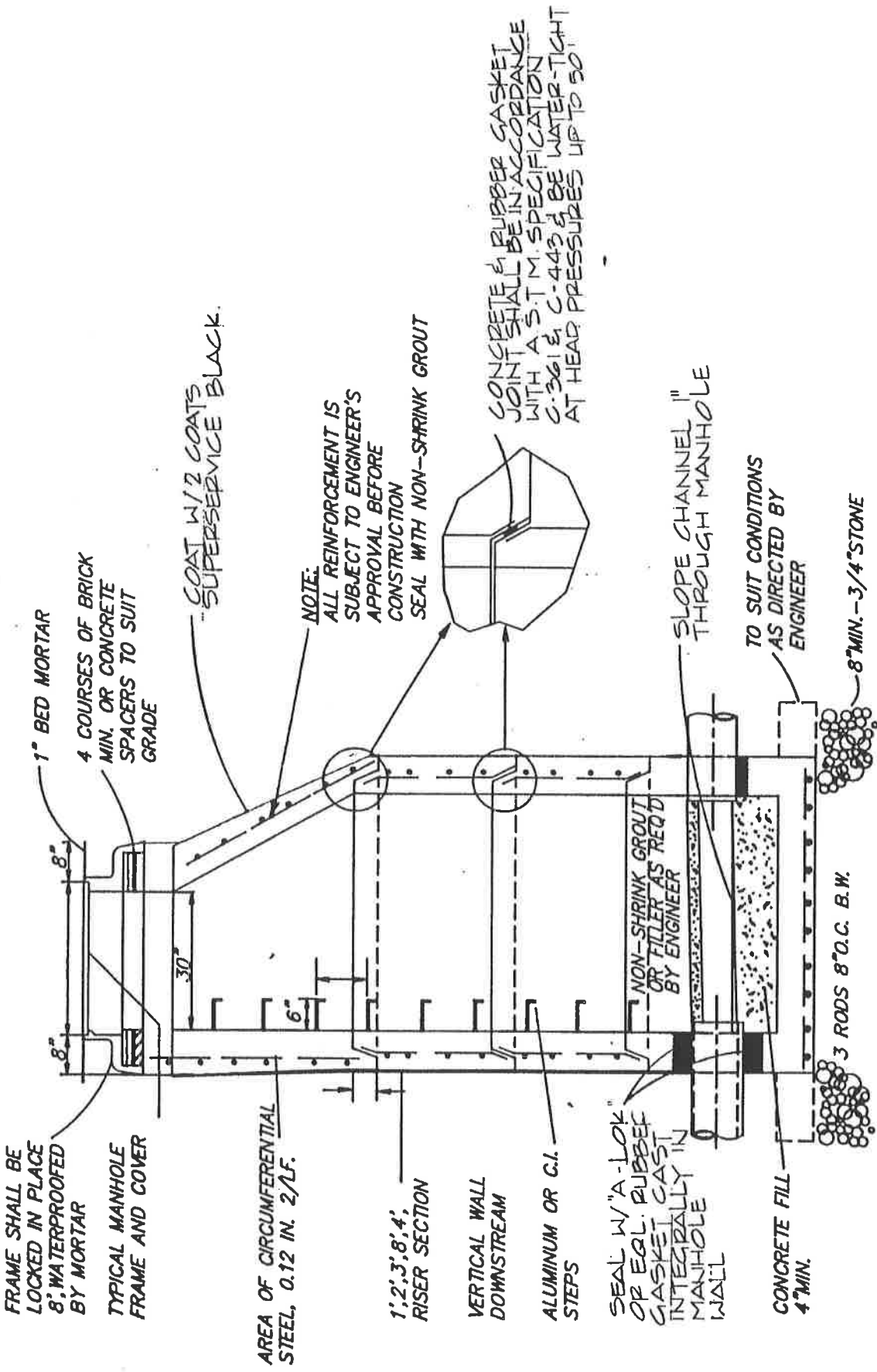

PRECAST CONCRETE MANHOLE

5/2" MIN. LD TO 12" PIPE
7" MIN 12" PIPE AND LD

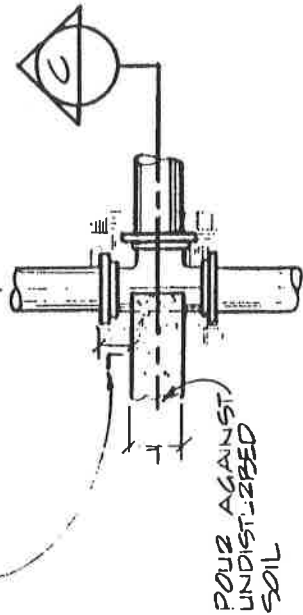

A PLAN

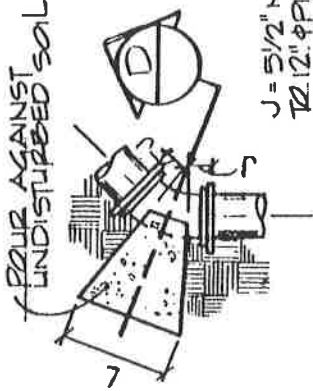

J = 5/2" MIN. UP
TO 12" PIPE 7"
MIN. 12" PIPE 4" UP

B PLAN

3000 PSI
CONC.

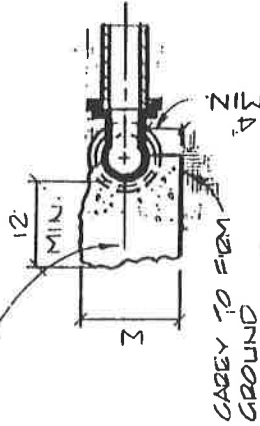

C SECTION

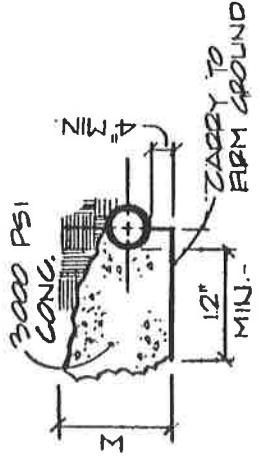

D SECTION

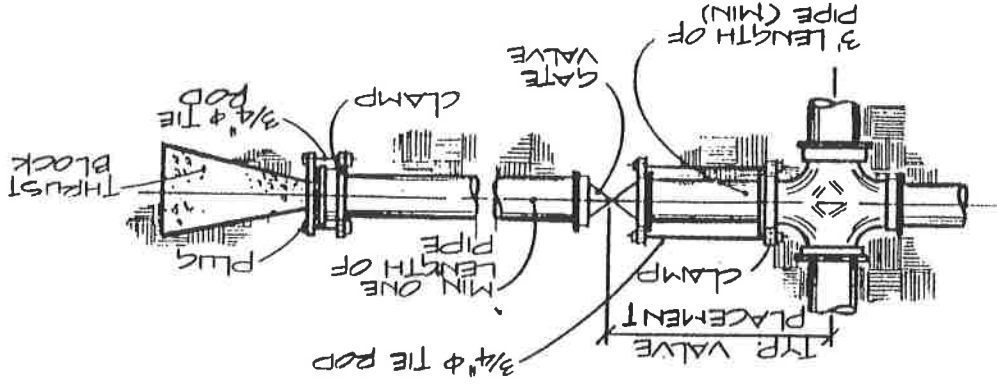

E DETAIL OF TEE
---NOT TO SCALE

F DETAIL OF BEND
NOT TO SCALE

*NOTE:

DRAWINGS TO BE USED WITH
THRUST BLOCK NOMOGRAPH ONLY!

THRUST BLOCK DETAIL

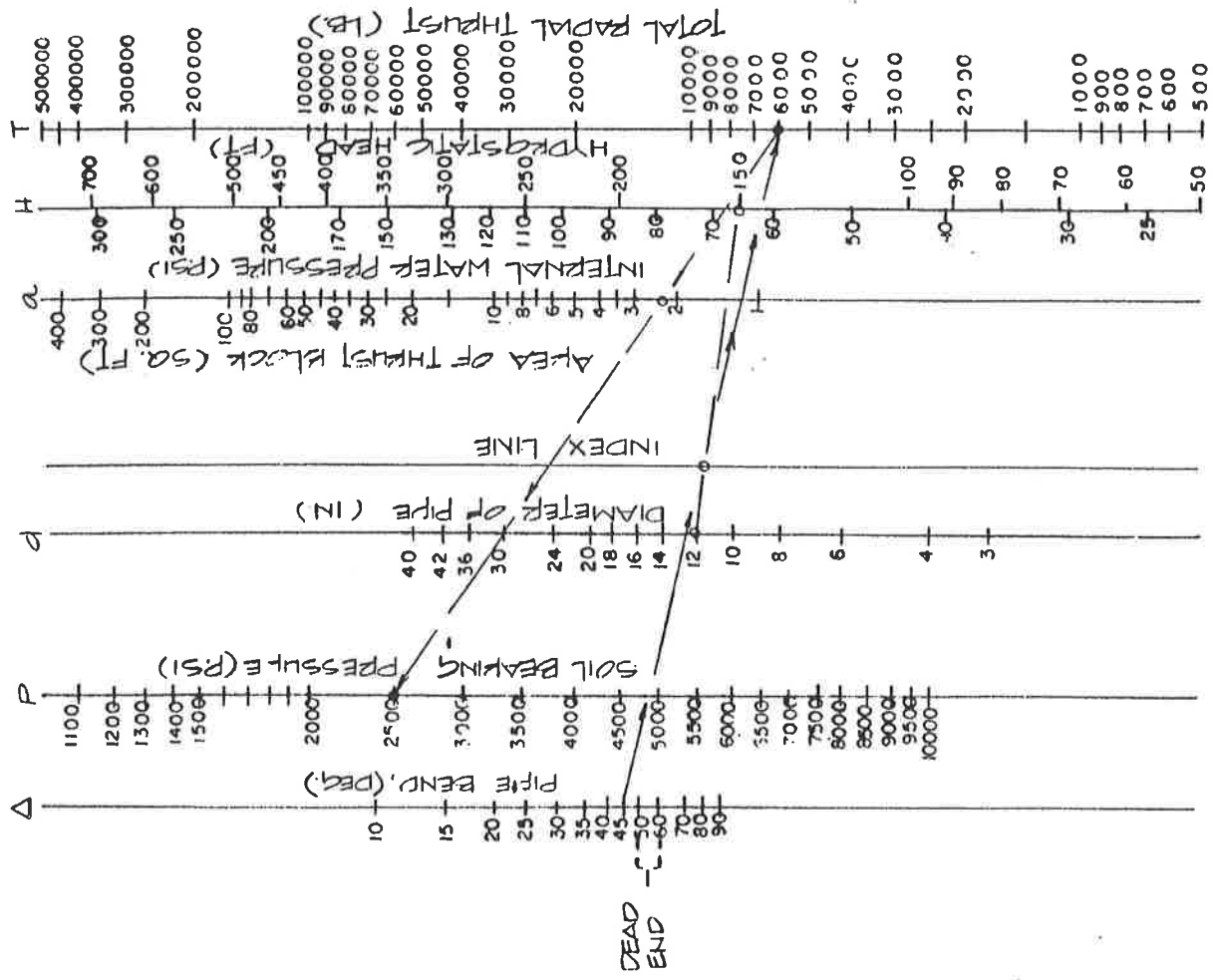

LEGEND

- H = HYDRAULIC HEAD (FT.)
- d = DIAMETER OF PIPE (IN.)
- Δ = PIPE BEND (DEGREE)
- T = TOTAL RADIAL THRUST (LB.)
- P = SOIL BEARING PRESSURE (P.S.I)
- a = AREA OF THRUST BLOCK (SQ. FT.)

NOTE:

EXAMPLE SHOWN ON GRAPH IS FOR A 12" 45° PIPE BEND SUBJECTED TO 150' HYDROSTATIC HEAD.

NOMOGRAPH FOR BEARING AREA OF THRUST BLOCKS

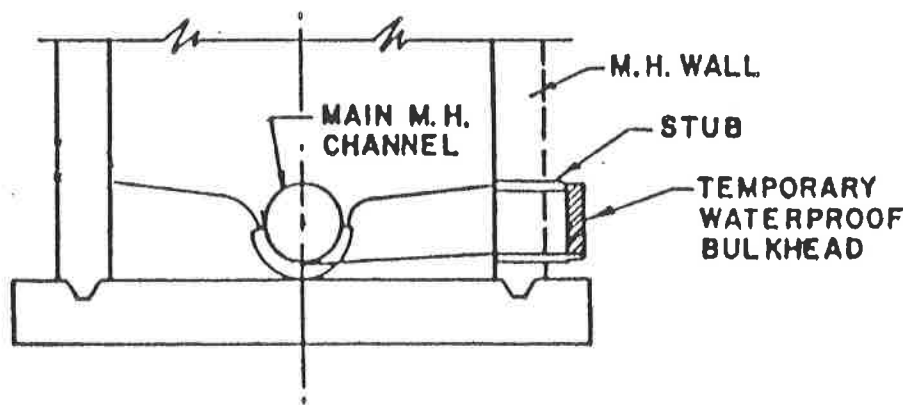

DETAIL OF MANHOLE STUB

SCALE: NONE

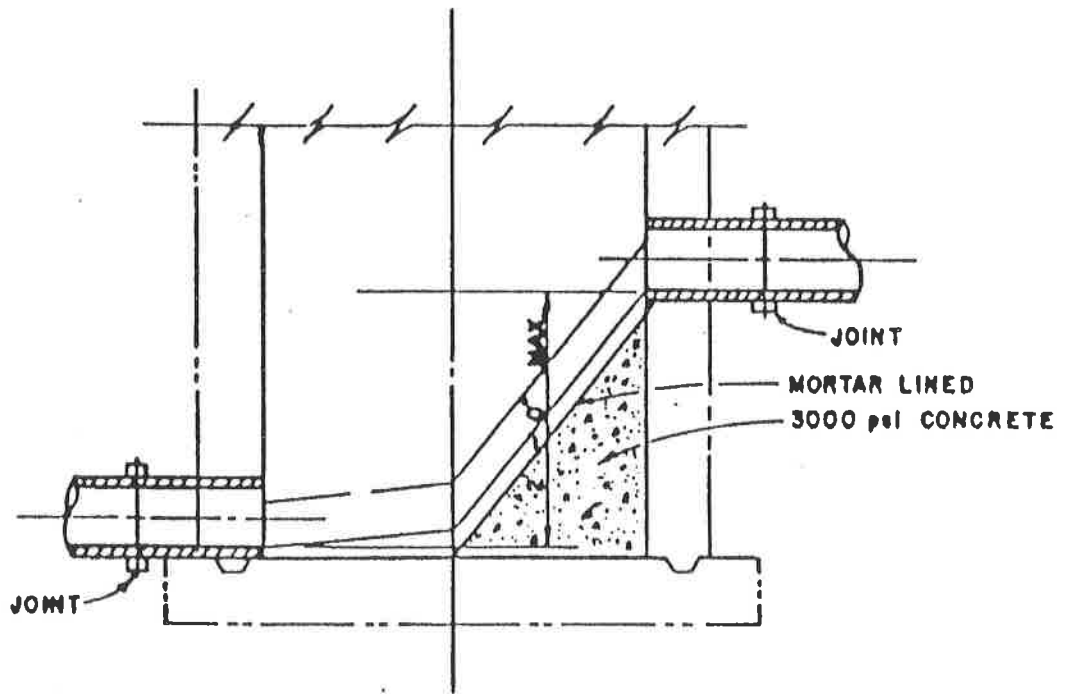

MANHOLE CHUTE

SCALE: NONE

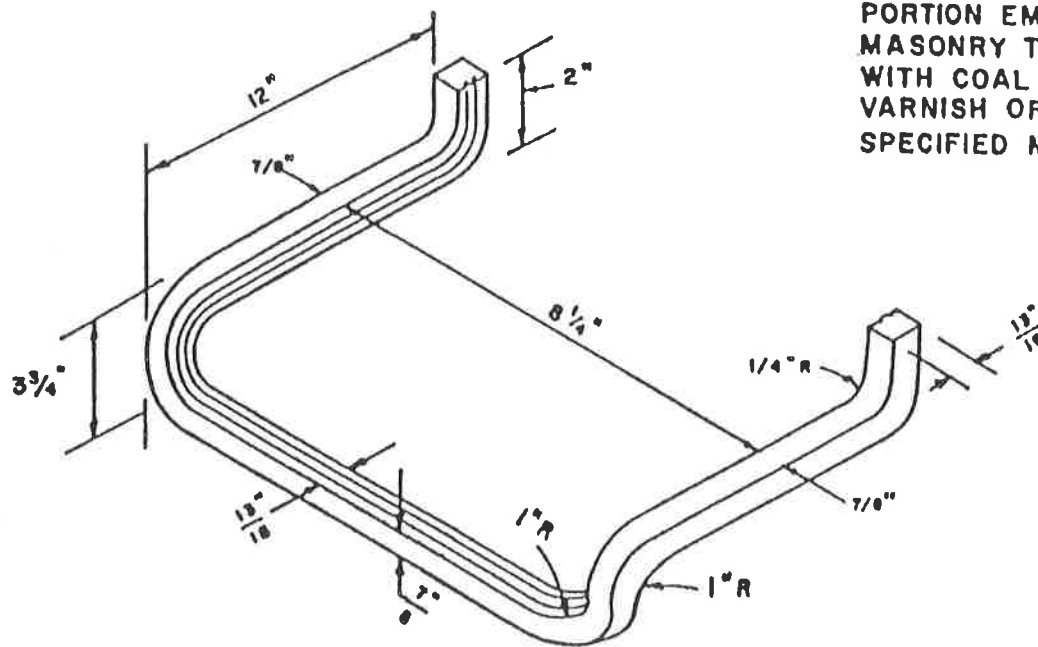

NOTE:

PORTION EMBEDDED IN
MASONRY TO BE COATED
WITH COAL TAR PITCH
VARNISH OR OTHER
SPECIFIED MATERIAL.

ALUMINUM MANHOLE STEP

SALE: NONE

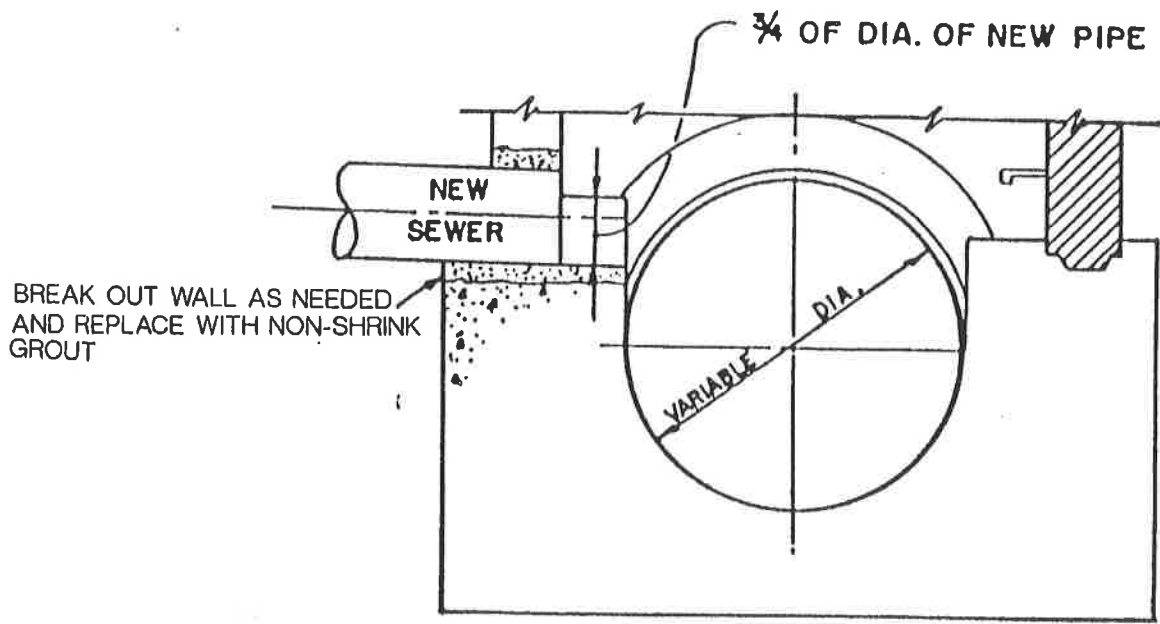

DETAIL OF CONNECTION TO EXISTING MANHOLE

SCALE: $\frac{1}{2}'' = 1'-0''$

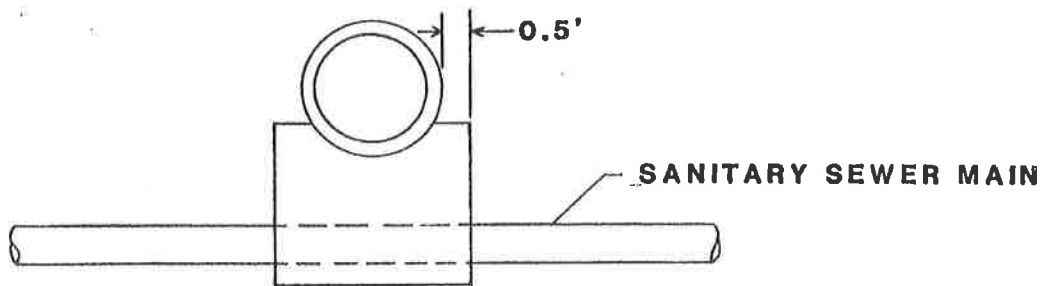
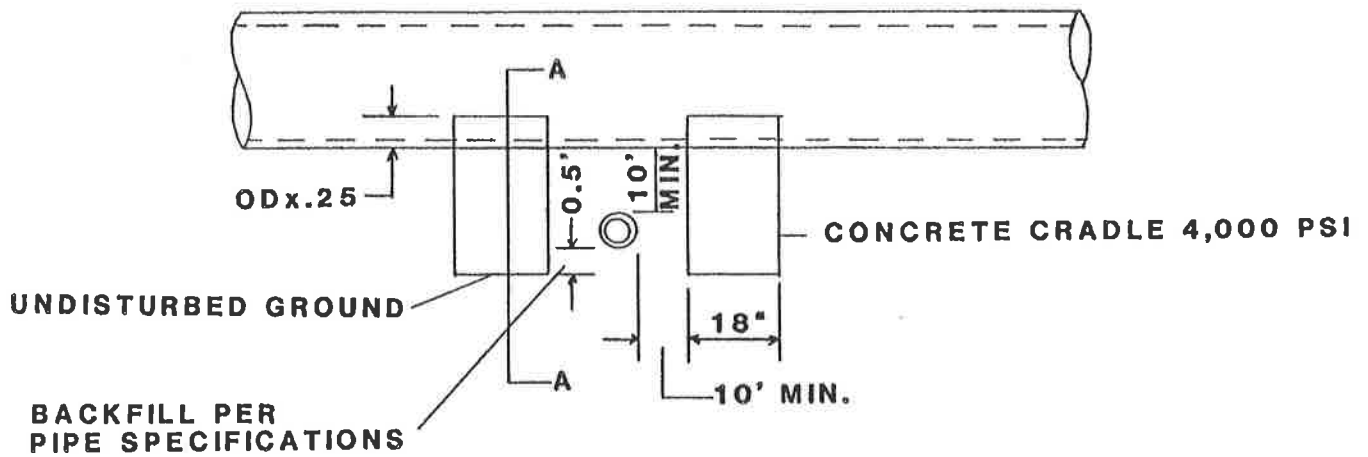

SECTION A-A

NOTES:

1. PROVIDE EIGHTEEN INCHES (18") VERTICAL CLEARANCE BETWEEN SEWER/WATER MAINS AND PIPES CROSSING ABOVE. IF THIS IS NOT POSSIBLE, SUPPORT THE TOP PIPE WITH CONCRETE CRADLES. IN NO CASE SHALL THE VERTICAL CLEARANCE BETWEEN PIPES BE LESS THAN TWELVE INCHES (12").
2. PROVIDE 4'-0" MINIMUM COVER OVER WATER MAINS AND SERVICE CONNECTIONS.

CONCRETE CRADLE DETAIL

SPECIFIED CLASS OF P.V.C. PIPE
WITH 3'-12" OF COVER

BEDDING AND INITIAL BACKFILL
REQUIREMENTS FOR SPECIFIED PIPE
CLASS & COVER CONDITION

SPECIFIED CLASS OF P.V.C. PIPE
WITH 12'-20" OF COVER

CLASS 150
SDR-18

CLASS 200
SDR-14

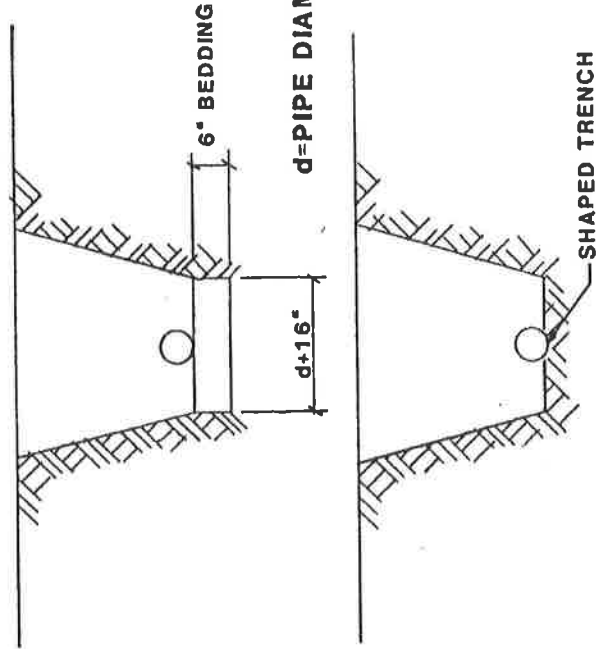

CLASS 200
SDR-14

N/A

P.V.C. GRAVITY SANITARY SEWER INSTALLATION

APPLICATION FORMS

REQUEST FOR PARTIAL PAYMENT AGREEMENT

NAME OF OWNER:

MAILING ADDRESS:

SERVICE ADDRESS:

WTMUA ACCOUNT #: _____

TOTAL AMOUNT DUE \$ _____

as of _____ 19__.

The undersigned owner requests a partial payment agreement to satisfy the water and/or sewer service fees. The undersigned proposes to pay \$ _____ as a down payment and \$ _____/month for _____ months.

The undersigned understands the current quarterly billings rendered after the above date must be paid on a current basis exclusive from the monthly payment required in the partial payment agreement.

TENTATIVE WATER
Application No. _____

Filed _____

THE WEYMOUTH TOWNSHIP MUNICIPAL UTILITIES AUTHORITY

Weymouth Township, New Jersey

Application for TENTATIVE APPROVAL OF WATER SYSTEM AND APPURTENANCES in the Township of Weymouth, County of Atlantic, State of New Jersey. (Application must be filed with the Authority 15 days in advance of a regular meeting of the Authority).

This application must be filed in duplicate accompanied by the following fees: a) an application fee of \$20/unit (minimum \$50.00); b) 2% of the estimated cost of construction (minimum \$1,000.00) as determined by the applicant's engineer, subject to the review and approval of the Authority's engineer.

Application is hereby made for TENTATIVE APPROVAL of the PRELIMINARY PLAN OF WATER SYSTEM AND APPURTENANCES. (Approval expires 2 years from date thereof).

1. Applicant's Name _____
Address: _____ Phone _____
2. Name and address of present owner (if other than No. 1 above).
Name _____ Address _____
3. Interest of applicant if other than owner:

4. Date classified as major subdivision by the Weymouth Township Planning Board _____
5. Location of subdivision _____
(neighborhood or section map)

(street) (tax map block) (lot numbers)
6. Number of proposed lots to be served _____
7. Area of entire tract _____, portion being served _____

8. Development plans:

a. Sell lots only (yes) or (no) _____

b. Construction of houses for sale _____

c. Other _____

9. Name, address, and profession of person designing preliminary plan

Name _____ Profession _____

Address _____ Phone _____

10. Does applicant or owner agree to convey by deed to the Weymouth Township MUA easements to all areas on preliminary plan showing water facilities and all rights to the water system?

11. Describe your proposal for water service

12. If water system is required, will applicant post Performance and Maintenance Guarantee?

13. List plans and other material accompanying application and number of each.

	Item	Number
a.	_____	_____
b.	_____	_____
c.	_____	_____
d.	_____	_____
e.	_____	_____
f.	_____	_____

14. Attach 7 black on white prints of your preliminary plan.

Signature of Applicant

_____ Date _____

Make all checks payable to
THE WEYMOUTH TOWNSHIP MUNICIPAL UTILITIES AUTHORITY

DO NOT WRITE BELOW THIS LINE

Date received and fee collected by Authority _____ (Date) _____ (Fee Paid)

Recommendations of the Authority's Engineer

Action of the Weymouth Township Municipal Utilities Authority

Date _____ Approved _____

Date _____ Disapproved _____ Reason _____

Date _____ Secretary _____

FINAL WATER
Application No. _____

Filed _____

THE WEYMOUTH TOWNSHIP MUNICIPAL UTILITIES AUTHORITY

Weymouth Township, New Jersey

Application for FINAL APPROVAL OF WATER SYSTEM AND APPURTENANCES in the Township of Weymouth, County of Atlantic, State of New Jersey.

This application must be filed in duplicate fifteen days in advance of a regular meeting of the Authority accompanied by a fee of 2% of the estimated cost of construction (minimum \$1,000.00) as determined by the Applicant's Engineer, subject to the review and approval of the Authority's Engineer.

Application is hereby made for final approval of the FINAL PLAN OF WATER SYSTEM AND APPURTENANCES. (Approval shall expire 2 years from date thereof)

1. Applicant's Name _____
Address _____ Phone _____
2. Name and address of present owner (if other than No. 1 above)
Name _____ Address _____
3. Preliminary Application No. _____ Date Approved _____
4. Tentative Application No. _____ Date Approved _____
5. Does the Final Plan follow exactly the Preliminary Plan in regard to details and area covered? _____ If not, indicate material changes.

6. Date of filing Final Plan with the Weymouth Township Planning Board

7. Number of lots proposed for Final Approval _____

8. List of maps and other material accompanying application and number of each item

	ITEM	NUMBER
a.	_____	_____
b.	_____	_____
c.	_____	_____
d.	_____	_____
e.	_____	_____
f.	_____	_____
g.	_____	_____

9. Applicant's Engineer's estimated cost of construction including rights-of-ways, and easements.

\$ _____

10. Calendar days after final approval is given by the Authority to complete the entire job _____.

Signature of Applicant

_____ DATE _____

Make all checks payable to
THE WEYMOUTH TOWNSHIP MUNICIPAL UTILITIES AUTHORITY

DO NOT WRITE BELOW THIS LINE

Date received and fee collected by Authority _____
(Date) (Fee Paid)

Recommendations of the Authority's Engineer

Authority Engineer's Estimated Cost of Construction \$ _____

Action of the Weymouth Township Municipal Utilities Authority

Date _____ Approved _____

Date _____ Disapproved _____

Reason _____

Date _____ Secretary _____

TENTATIVE SEWER
APPLICATION NO. _____

FILED _____

THE WEYMOUTH TOWNSHIP MUNICIPAL UTILITIES AUTHORITY

Weymouth Township, New Jersey

APPLICATION FOR TENTATIVE APPROVAL OF SANITARY SEWERS AND APPURTENANCES IN THE TOWNSHIP OF WEYMOUTH (Application must be filed with the Authority 15 days in advance of a regular meeting of the Authority).

This application must be filed in duplicate, accompanied by the following fees: a) an application fee of \$20/unit (minimum \$50.00); b) 2% of the estimated cost of construction (minimum \$1,000.00) as determined by the applicant's engineer, subject to the review and approval of the Authority's engineer.

Application is hereby made for tentative approval of the Preliminary Plan of sanitary sewers and appurtenances. (Approval expires in 2 years)

1. Applicant's Name _____
Address _____ Phone _____
2. Name and address of present owner (if other than No. 1 above)
Name _____
Address _____ Phone _____
3. Interest of applicant if other than owner _____

4. Date classified as major subdivision by the Weymouth Township Planning Board _____
5. Location of subdivision _____
(neighborhood or section name)
_____, _____, _____
(street) (tax map block) (lot numbers)
6. Number of proposed lots to be sewered _____
7. Area of entire tract _____ Portion to be sewered _____

8. Development Plans:

- a. Sell lots only? (Yes or No) _____
- b. Construction of houses for sale? (Yes or No) _____
- c. Other _____

9. Name and profession of person designing preliminary plan.

Name _____ Profession _____
Address _____ Phone _____

10. Does applicant or owner agree to convey by deed to the Weymouth Township Municipal Utilities Authority easements to all areas on preliminary plan showing sanitary sewer and all rights to sewer system? _____

11. Applicant's engineer's estimate of entire cost of construction including rights-of-way, and easements \$ _____

12. Describe your proposal for sewage disposal

- 1. _____
- 2. _____
- 3. _____

13. If sewers are required, will applicant post Performance and Maintenance Guarantees? _____

14. List plans and other material accompanying application and number of each. (Attach additional sheets if necessary)

	Item	Number
a.	_____	_____
b.	_____	_____
c.	_____	_____
d.	_____	_____

15. Attach seven (7) black on white prints of your preliminary plan.

Signature of Applicant _____ Date _____

Make all checks payable to
THE WEYMOUTH TOWNSHIP MUNICIPAL UTILITIES AUTHORITY

DO NOT WRITE BELOW THIS LINE

Date received and fee collected by Authority

_____ Date

_____ Fee Paid

Action by the Weymouth Township Municipal Utilities Authority

Date: _____ Approved _____ Disapproved _____

Recommendation of Authority _____

The Weymouth Township Municipal Utilities Authority's Engineer's

Approval _____

_____ Date

_____ Secretary

FINAL SEWER
APPLICATION NO. _____

FILED _____

THE WEYMOUTH TOWNSHIP MUNICIPAL UTILITIES AUTHORITY

Weymouth Township, New Jersey

APPLICATION FOR FINAL APPROVAL OF SANITARY SEWERS AND APPURTENANCES IN THE TOWNSHIP OF WEYMOUTH. (Application must be filed fifteen days in advance of a regular meeting of the Authority).

This application must be filed in duplicate, accompanied by a fee of 2% of the applicant's engineer's estimate of the entire cost of construction (minimum \$1,000.00), including the rights-of-way, and "as-built" plans, subject to review and approval of the Authority's Engineer.

Application is hereby made for final approval of plan of sanitary sewers and appurtenances. (Approval expires in 2 years):

1. Applicant's Name _____
Address _____ Phone _____
2. Name and address of present owner (if other than No. 1 above).
Name _____
Address _____ Phone _____
3. Preliminary Application No. _____ Date Approved _____
4. Tentative Application No. _____ Date Approved _____
5. Does the Final Plan follow exactly the Preliminary Plan in regard to details and area covered? _____
if not, indicate material changes _____

6. Date of filing final plan with the Weymouth Township Planning Board

7. Number of lots proposed for Final Approval _____

8. List of maps and other material accompanying application and number of each.

	Item	Number
a.	_____	_____
b.	_____	_____
c.	_____	_____
d.	_____	_____
e.	_____	_____
f.	_____	_____
g.	_____	_____

9. Applicant's engineer's estimated cost of construction, including rights-of-way, and easements

10. Calendar days required, after approval is given by the Authority, to complete the entire job _____

Signature of Applicant _____ Date _____

Make all checks payable to
THE WEYMOUTH TOWNSHIP MUNICIPAL UTILITIES AUTHORITY

DO NOT WRITE BELOW THIS LINE

Date received and fee collected by Authority _____ (Date) _____ (Fee Paid)

Recommendations of the Authority's Engineer

Authority Engineer's Estimated Cost of Construction \$ _____

Action of the Weymouth Township Municipal Utilities Authority

Date _____ Approved _____

Date _____ Disapproved _____

Reason _____

Date _____ Secretary _____

INDIVIDUAL

WEYMOUTH TOWNSHIP MUNICIPAL UTILITIES AUTHORITY

RESIDENTIAL APPLICATION FOR SEWER AND WATER CONNECTIONS

SERVICE APPLIED FOR: SEWER CONNECTION () ; WATER CONNECTION ()

APPLICANT _____ DATE _____

BLOCK _____ LOT _____ STREET ADDRESS _____

AWARD DATE _____ CONNECTION FEE _____

CONNECTION FEE PAYMENT DATE _____

YEARLY SERVICE CHARGE BEGINS _____

I, _____, HEREBY CERTIFY THAT I HAVE READ
(Applicant's Name)

AND DO UNDERSTAND THE POLICY GOVERNING THE ALLOCATION OF A SEWER AND/OR WATER CONNECTION.

Applicant's Signature

Authority Representative

WEYMOUTH TOWNSHIP MUNICIPAL UTILITIES AUTHORITY

COMMERCIAL APPLICATION FOR SEWER AND WATER CONNECTIONS

SERVICE APPLIED FOR: SEWER CONNECTION () ; WATER CONNECTION ()

APPLICANT _____ DATE _____

PROJECT _____

NUMBER OF DCU'S _____ CONNECTION FEE _____

DATE APPLICATION SUBMITTED _____

1. PHASING OR CONSTRUCTION SCHEDULE _____

2. SCHEDULE OF APPROVALS OR ESTIMATES:

A. PLANNING BOARD _____

B. CAFRA _____

C. PINELANDS _____

D. BUILDING PERMIT _____

E. M.U.A. _____

F. COUNTY _____

G. OTHER _____

LETTER OF VIABILITY DATE _____

90 DAY PERIOD OF SECURE COMMITMENT OF
FINANCING VERIFICATION _____

FORMAL AWARD DATE _____

CONNECTION FEE PAYMENT DATE _____

YEARLY SERVICE CHARGES BEGINS' _____

CONNECTION FEE PAYMENTS ARE NON-REFUNDABLE

I, _____, HEREBY AGREE TO THE CONDITIONS
AS SET FORTH ABOVE.

DATE

APPLICANT

AUTHORITY REPRESENTATIVE